

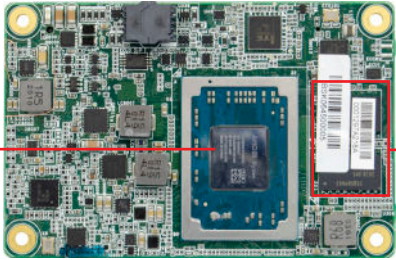

GH9A3

R1000

AMD Ryzen™
R1000
Series



DDR4

TOP

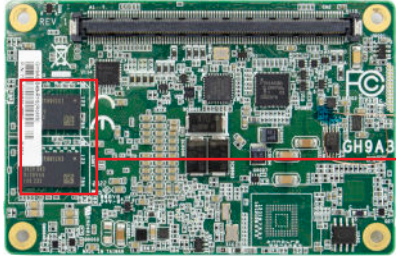

DDR4

BOTTOM

Mechanical Drawing

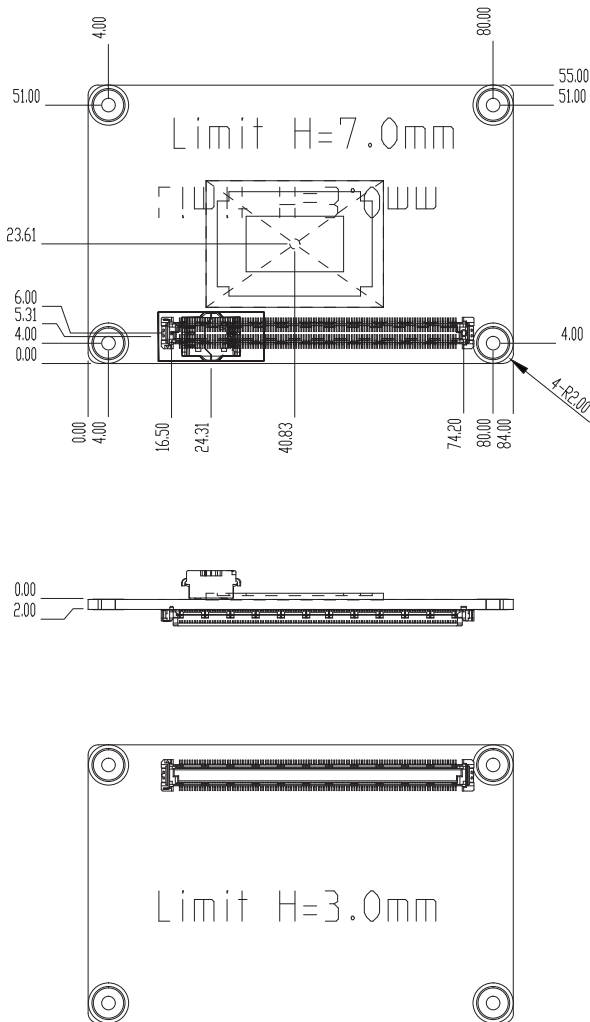

Features

- Single Channel DDR4 2400MHz Memory Down up to 8GB
- 1 LVDS/eDP, 1 DDI (HDMI/DP)
Supports dual displays: DDI + LVDS/eDP
- DP++ resolution supports up to 3840x2160 @ 60Hz
- Multiple expansions: 3 PCIe x1
- Rich I/O: 1 GbE, 2 USB 3.1, 8 USB 2.0



Block Diagram

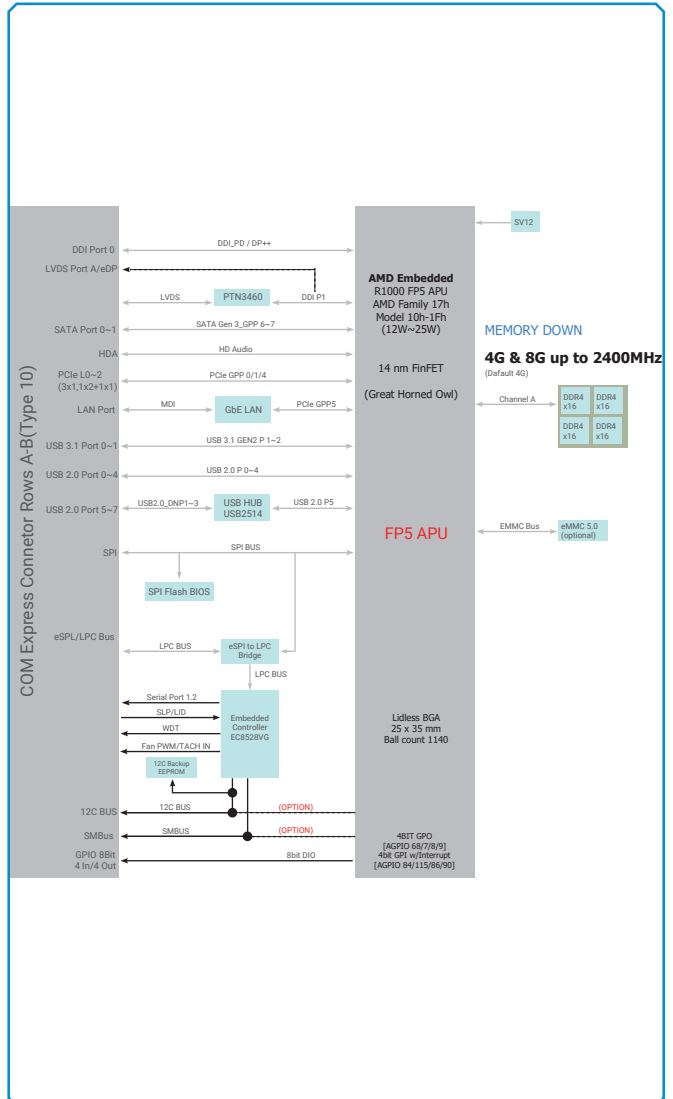

► Specifications

SYSTEM	Processor	AMD® Ryzen™ Embedded R1606G, Dual Core, 1MB Cache, 3 CU, 2.6GHz (3.5GHz), 12W AMD® Ryzen™ Embedded R1505G, Dual Core, 1MB Cache, 3 CU, 2.4GHz (3.3GHz), 12W AMD® Ryzen™ Embedded R1000 series	
	Memory	4GB/8GB Memory Down	Single Channel DDR4 2400MHz
	BIOS	SPI 64Mbit (default supports fTPM2.0)	
GRAPHICS	Controller	Radeon™ Vega 3 Graphics	
	Feature	OpenGL 5.0, DirectX 12, OpenCL 2.1 HW Decode: AVC/H.264, MPEG2, VC1, WMV9, JPEG/MJPEG, HEVC/H.265, VP8, VP9, MVC HW Encode: AVC/H.264, JPEG/MJPEG, HEVC/H.265, VP8, VP9, MVC	
	Display	1 x DDI (HDMI/DP++) 1 x LVDS/eDP	LVDS: single channel 24-bit, resolution up to 1366x768 @ 60Hz HDMI: resolution up to 4096x2160 @ 24Hz DP++: resolution up to 3840x2160 @ 60Hz eDP: resolution up to 3840x2160 @ 60Hz
	Dual Display	DDI + LVDS	DDI + eDP
EXPANSION	Interface	3 x PCIe x1 (Gen 3) 1 x SDIO 1 x LPC 1 x I ² C 1 x SMBus 1 x SPI 2 x UART (TX/RX)	
AUDIO	Interface	HD Audio	
ETHERNET	Controller	Realtek RTL8111/RTL8119 (Option)	
I/O	USB	2 x USB 3.1 8 x USB 2.0	
	SATA	2 x SATA 3.0 (up to 6Gb/s)	
	GPIO	1 x 8-bit GPIO	
SECURITY	TPM	BIOS default support fTPM, TPM2.0 by request.	
WATCHDOG TIMER	Output & Interval	System Reset, Programmable via Software from 1 to 255 Seconds	
POWER	Type	4.75V~20V, 5VSB, VCC_RTC (ATX mode)	4.75V~20V, VCC_RTC (AT mode)
	Consumption	TBD	
OS SUPPORT (UEFI ONLY)		Windows 10 IoT Enterprise 64-bit	Linux
ENVIRONMENT	Temperature	Operating: 0 to 60°C -40 to 85°C	Storage: -40 to 85°C
	Humidity	Operating: 5 to 90% RH	Storage: 5 to 90% RH
	MTBF	TBD	
MECHANICAL	Dimensions	COM Express® Mini	84mm (3.30") x 55mm (2.16")
	Compliance	PICMG COM Express® R3.0, Type 10	

► Ordering Information

Model Name	P/N	Processor	Memory	DIO/SDIO	LVDS/eDP	GbE	USB 3.0	USB 2.0	Power	Thermal	Temp.
GH9A3-B40-R15	770-GH9A31-000G	R1505G	4G	DIO	LVDS	1	2	8	ATX/AT	Heat Sink	0 to 60°C
GH9A3-T40-R16	770-GH9A31-100G	R1506G	4G	DIO	LVDS	1	2	8	ATX/AT	Cooler	-40 to 85°C
GH9A3-T80-R16	770-GH9A31-200G	R1506G	8G	SDIO	LVDS	1	2	8	ATX/AT	Cooler	-40 to 85°C

► Packing List

• 1 GH9A3 board	
• 1 Heat sink (for 0 to 60°C)	A71-008164-000G
• 1 Cooler (for -40 to 85°C)	A71-108133-000G

► Optional Items

• COM100-B carrier board kit	770-COM104-000G
------------------------------	-----------------