

KOE

JDI Group

Kaohsiung Opto-Electronics Inc.

FOR MESSRS : _____

DATE : Aug. 24th ,2020

CUSTOMER'S ACCEPTANCE SPECIFICATIONS

TX23D203VM0BAA

Contents

No.	ITEM	SHEET No.	PAGE
1	COVER	7B64PS 2701-TX23D203VM0BAA-2	1-1/1
2	RECORD OF REVISION	7B64PS 2702-TX23D203VM0BAA-2	2-1/1
3	GENERAL DATA	7B64PS 2703-TX23D203VM0BAA-2	3-1/1
4	ABSOLUTE MAXIMUM RATINGS	7B64PS 2704-TX23D203VM0BAA-2	4-1/1
5	ELECTRICAL CHARACTERISTICS	7B64PS 2705-TX23D203VM0BAA-2	5-1/2~2/2
6	OPTICAL CHARACTERISTICS	7B64PS 2706-TX23D203VM0BAA-2	6-1/2~2/2
7	BLOCK DIAGRAM	7B64PS 2707-TX23D203VM0BAA-2	7-1/1
8	RELIABILITY TESTS	7B64PS 2708-TX23D203VM0BAA-2	8-1/1
9	LCD INTERFACE	7B64PS 2709-TX23D203VM0BAA-2	9-1/9~9/9
10	OUTLINE DIMENSIONS	7B64PS 2710-TX23D203VM0BAA-2	10-1/2~2/2
11	APPEARANCE STANDARD	7B64PS 2711-TX23D203VM0BAA-2	11-1/3~3/3
12	PRECAUTIONS	7B64PS 2712-TX23D203VM0BAA-2	12-1/2~2/2
13	DESIGNATION OF LOT MARK	7B64PS 2713-TX23D203VM0BAA-2	13-1/1

ACCEPTED BY: _____

PROPOSED BY: Oblack Tsai

2. RECORD OF REVISION

DATE	SHEET No.	SUMMARY
Aug.24,'20	7B64PS 2704 – TX23D203VM0BAA-2 Page 4-1/1	4. ABSOLUTE MAXIMUM RATINGS Revised : Operating Temperature Min. -30°C → -40°C
	7B64PS 2708 - TX23D203VM0BAA-2 Page 8-1/1	8. RELIABILITY TESTS Revised : Low Temperature -30°C → -40°C

3. GENERAL DATA

3.1 DISPLAY FEATURES

This module is a 9" WVGA of 16:9 format of amorphous silicon TFT. The pixel format is vertical stripe and sub pixels are arranged as R(red), G(green), B(blue) sequentially .This display is RoHS compliant , and COG (chip on glass) technology and LED backlight are applied on this display.

Part Name	TX23D203VM0BAA
Module Dimensions	218.0(W) mm x 135.0(H) mm x 11.15 (D) mm
LCD Active Area	196.8(W) mm x 118.08(H) mm
Pixel Pitch	0.246(W) mm x 0.246(H) mm
Resolution	800 x 3(RGB)(W) x 480(H) Dots
Color Pixel Arrangement	R, G, B Vertical stripe
LCD Type	Transmissive Color TFT; Normally Black
Display Type	Active Matrix
Number of Colors	16.7M Colors(6-bit RGB+ FRC)
Backlight	Light Emitting Diode (LED)
Weight	330 g (typ.)
Interface	LVDS ; 20 pins
Power Supply Voltage	3.3V for LCD ; 12.0V for Backlight
Power Consumption	1.2 W for LCD ; 4.8W for backlight
Viewing Direction	Super Wide Version (In Plane Switching)

4. ABSOLUTE MAXIMUM RATINGS

Item	Symbol	Min.	Max.	Unit	Remarks
Supply Voltage	V _{DD}	-0.3	4.0	V	-
Input Voltage of Logic	V _I	-0.3	V _{DD} +0.3	V	Note 1
Operating Temperature	T _{op}	-40	85	°C	Note 2
Storage Temperature	T _{st}	-40	90	°C	Note 2
Backlight Input Voltage	V _{LED}	-	15	V	-

Note 1: The rating is defined for the signal voltages of the interface such as DIM, SD, AMODE, CLK and pixel data pairs.

Note 2: The maximum rating is defined as above based on the chamber temperature, which might be different from ambient temperature after assembling the panel into the application. Moreover, some temperature-related phenomenon as below needed to be noticed:

- Background color, contrast and response time would be different in temperatures other than 25°C.
- Operating under high temperature will shorten LED lifetime.

5. ELECTRICAL CHARACTERISTICS

5.1 LCD CHARACTERISTICS

$T_a = 25\text{ }^\circ\text{C}$, $V_{SS} = 0\text{V}$

Item	Symbol	Condition	Min.	Typ.	Max.	Unit	Remarks
Power Supply Voltage	V_{DD}	-	3.0	3.3	3.6	V	-
Input Voltage of Logic	V_I	"H" level	-	-	+100	mV	Note 1
		"L" level	-100	-	-		
Signal Input Voltage	V_I	"H" level	$0.7V_{DD}$	-	V_{DD}	V	CMOS Level
		"L" level	0	-	$0.3V_{DD}$		
Power Supply Current	I_{DD}	$V_{DD}-V_{SS}=3.3\text{V}$	330	370	430	mA	Note 2,3
Frame Frequency	f_{Frame}			60	75	Hz	-
DCLK Frequency	f_{CLK}	-	-	33.3	35	MHz	

Note 1: VCM 1.2V is common mode voltage of LVDS transmitter and receiver. The input terminal of LVDS receiver is terminated with 100Ω .

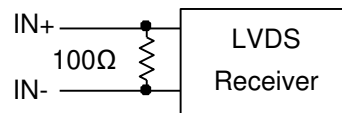

Note 2: An all white check pattern is used when measuring I_{DD} . f_{Frame} is set to 60 Hz.

Note 3: 1.0A fuse is applied in the module for I_{DD} . For display activation and protection purpose, power supply is recommended larger than 2.5A to start the display and break fuse once any short circuit occurred.

5.2 BACKLIGHT CHARACTERISTICS

$T_a = 25^\circ\text{C}$

Item	Symbol	Condition	Min.	Typ.	Max.	Unit	Remarks
LED Input Voltage	V_{LED}	-	11.5	12.0	12.5	V	Note 1
LED Forward Current (Dim control)	I_{LED}	0V; 0% duty	360	400	440	mA	
		3.3VDC; 100% Duty	42	45	47		
LED lifetime	-	$I_{LED} = 400\text{mA}$	-	70K	-	hrs	Note 2

Note 1: As Fig. 5.1 shown, LED current is constant, 400mA, controlled by the LED driver when applying 12V.

Note 2: The estimated lifetime is specified as the time to reduce 50% brightness by applying 400mA at 25°C .

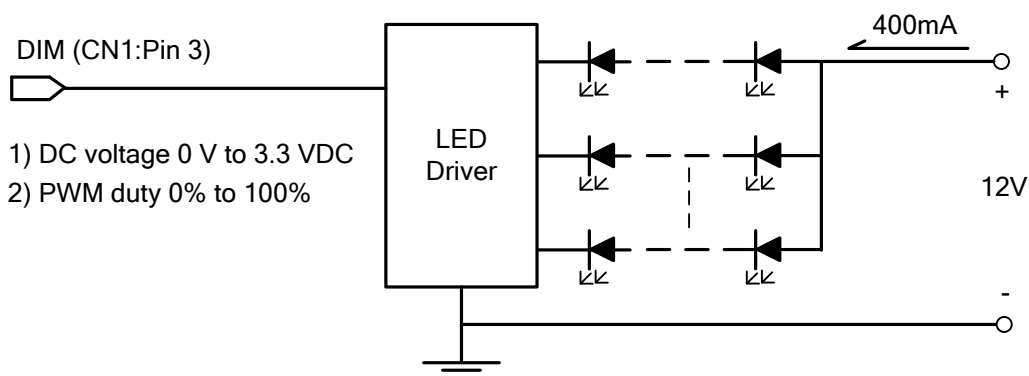

Fig. 5.1

6. OPTICAL CHARACTERISTICS

The optical characteristics are measured based on the conditions as below:

- Supplying the signals and voltages defined in the section of electrical characteristics.
- The backlight unit needs to be turned on for 15 minutes.
- The ambient temperature is 25 °C .
- In the dark room around 100 lx, the equipment has been set for the measurements as shown in Fig 6.1.

$$T_a = 25\text{ }^\circ\text{C}, f_{Frame} = 60\text{ Hz}, V_{DD} = 3.3\text{V}$$

Item	Symbol	Condition	Min.	Typ.	Max.	Unit	Remarks	
Brightness of White	-	$\phi = 0^\circ, \theta = 0^\circ,$ $I_{LED} = 400\text{mA}$	800	1000	-	cd/m ²	Note 1	
Brightness Uniformity	-		75	-	-	%	Note 2	
Contrast Ratio	CR		700	1000	-	-	Note 3	
Response Time (Rising + Falling)	Tr + Tf	$\phi = 0^\circ, \theta = 0^\circ$	-	40	-	ms	Note 4	
NTSC Ratio	-	$\phi = 0^\circ, \theta = 0^\circ$	-	72	-	%	-	
Viewing Angle	θ_x	$\phi = 0^\circ, CR \geq 10$	-	85	-	Degree	Note 5	
	$\theta_{x'}$	$\phi = 180^\circ, CR \geq 10$	-	85	-			
	θ_y	$\phi = 90^\circ, CR \geq 10$	-	85	-			
	$\theta_{y'}$	$\phi = 270^\circ, CR \geq 10$	-	85	-			
Color Chromaticity	Red	X	$\phi = 0^\circ, \theta = 0^\circ$	0.59	0.64	0.69	-	Note 6
		Y		0.30	0.35	0.40		
	Green	X		0.27	0.32	0.37		
		Y		0.57	0.62	0.67		
	Blue	X		0.09	0.14	0.19		
		Y		0.01	0.06	0.11		
	White	X		0.25	0.30	0.35		
		Y		0.27	0.32	0.37		

Note 1: The brightness is measured from the panel center point, P5 in Fig. 6.2, for the typical value.

Note 2: The brightness uniformity is calculated by the equation as below:

$$\text{Brightness uniformity} = \frac{\text{Min. Brightness}}{\text{Max. Brightness}} \times 100\%$$

, which is based on the brightness values of the 9 points measured by BM-5 as shown in Fig. 6.2.

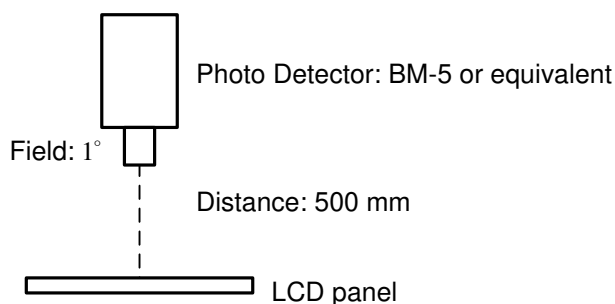

Fig. 6.1

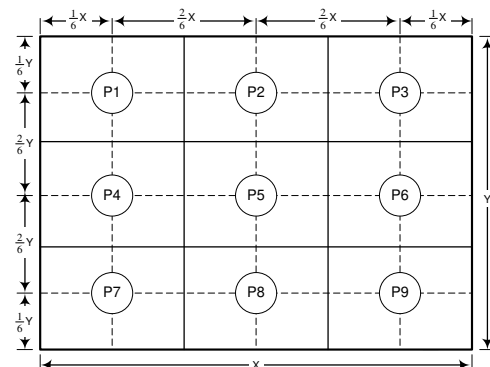

Fig. 6.2

Note 3: The Contrast Ratio is measured from the center point of the panel, P5, and defined as the following equation:

$$CR = \frac{\text{Brightness of White}}{\text{Brightness of Black}}$$

Note 4: The definition of response time is shown in Fig. 6.3. The rising time is the period from 10% brightness to 90% brightness when the data is from black to white. Oppositely, Falling time is the period from 90% brightness falling to 10% brightness.

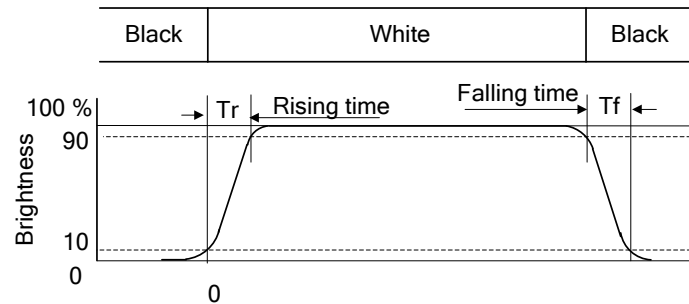

Fig 6.3

Note 5: The definition of viewing angle is shown in Fig. 6.4. Angle ϕ is used to represent viewing directions, for instance, $\phi = 270^\circ$ means 6 o'clock, and $\phi = 0^\circ$ means 3 o'clock. Moreover, angle θ is used to represent viewing angles from axis Z toward plane XY.

The display is super wide viewing angle version; 85° viewing angle can be obtained from each viewing direction.

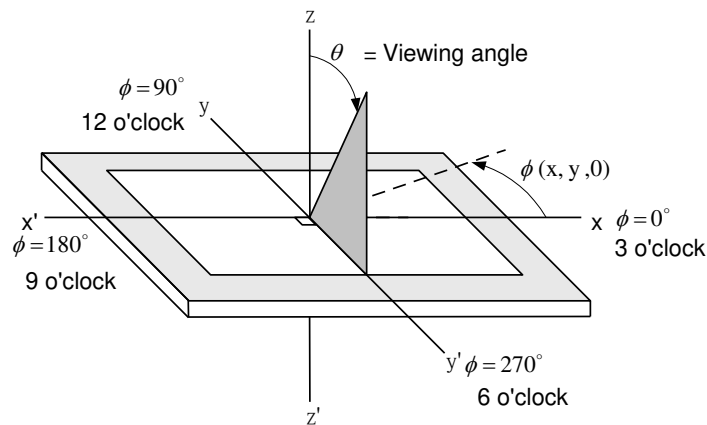
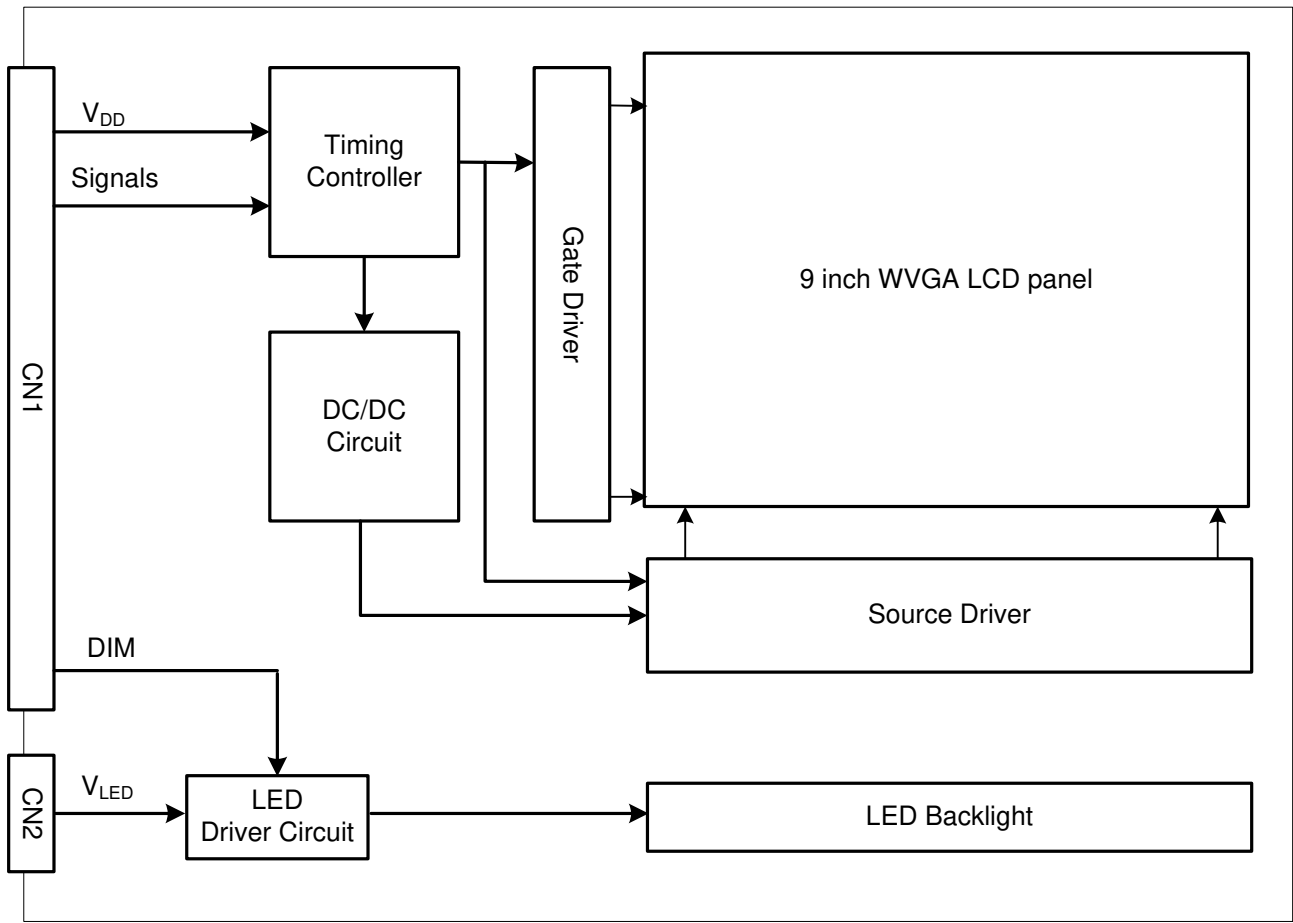

Fig 6.4

Note 6: The color chromaticity is measured from the center point of the panel, P5, as shown in Fig. 6.2.

7 BLOCK DIAGRAM



8. RELIABILITY TESTS

Test Item	Condition		
High Temperature	1) Operating 2) 85 °C		500 hrs
Low Temperature	1) Operating 2) -40 °C		500 hrs
High Temperature	1) Storage 2) 90 °C		500 hrs
Low Temperature	1) Storage 2) -40 °C		500 hrs
Heat Cycle	1) Operating 2) -30 °C ~80 °C	3) 3hrs~1hr~3hrs	500 hrs
Thermal Shock	1) Non-Operating 2) -35 °C ↔ 85 °C	3) 0.5 hr ↔ 0.5 hr	500 hrs
High Temperature & Humidity	1) Operating 2) 40 °C & 85%RH	3) Without condensation (Note3)	500 hrs
Vibration	1) Non-Operating 2) 10~200 Hz	3) 5G 4) X, Y, and Z directions	1 hr for each direction
Mechanical Shock	1) Non-Operating 2) 10 ms	3) 80G 4) ±X, ±Y and ±Z directions	Once for each direction
ESD	1) Operating 2) Tip:150 pF,330 Ω 3) Air discharge for glass: ± 12KV 4) Contact discharge for metal frame: ± 15KV		1) Glass: 9 points 2) Metal frame: 8 points (Note4)

Note 1: Display functionalities are inspected under the conditions defined in the specification after the reliability tests.

Note 2: The display is not guaranteed for use in corrosive gas environments.

Note 3: Under the condition of high temperature & humidity, if the temperature is higher than 40 °C, the humidity needs to be reduced as Fig. 8.1 shown.

Note 4: All pins of LCD interface (CN1) have been tested by ± 100V contact discharge of ESD under non-operating condition.

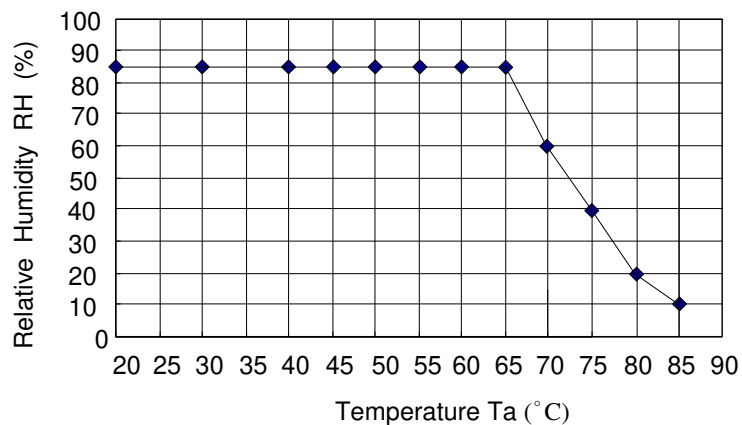

Fig. 8.1

9. LCD INTERFACE

9.1 INTERFACE PIN CONNECTIONS

The display interface connector CN1 is FI-SEB20P-HF13E made by JAE and more details of the connector are shown in the section of outline dimension. Pin assignment of LCD interface is as below:

Pin No.	Signal	Signal	Pin No.	Signal	Signal
1	V _{DD}	Power Supply (typ.+3.3V)	11	IN2-	Pixel Data
2	V _{DD}		12	IN2+	
3	DIM	Backlight diming (Note 3)	13	V _{SS}	GND
4	V _{SS}	GND	14	CLK IN-	Pixel Clock
5	IN0-	Pixel Data	15	CLK IN+	
6	IN0+		16	V _{SS}	GND
7	V _{SS}	GND	17	IN3-	Pixel Data
8	IN1-	Pixel Data	18	IN3+	
9	IN1+		19	SD	Scan Direction Control (Note 1)
10	V _{SS}	GND	20	AMODE	L:8bit(default),H:8bit/6bit

Note 1: Scan direction is available to be switched as below.

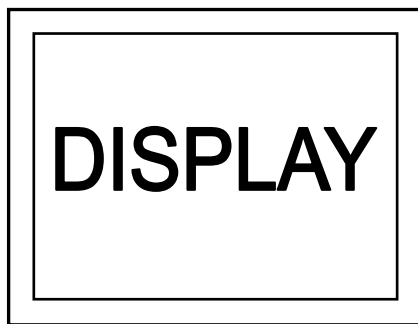

SD : Low or Open (Default)



SD : High

Note 2: In n- and n+ (n=0,1,2,3), CLK IN- and CLK IN+ should be wired by twist-pairs or side by side FPC patterns, respectively.

Note 3: Normal brightness: 0V or 0% PWM duty; Brightness control: 0V to 3.3V DC or 0% to 100% PWM duty.

The backlight interface connector CN2 is SM08B-SRSS-TB made by JST, and pin assignment of backlight is as below:

Pin No.	Signal	Function
1~3	V _{LED+}	Power Supply for LED(12V)
4~5	NC	No Connection
6~8	V _{LED-}	GND

9.2 LVDS INTERFACE

1) 8Bit Mode (AMODE = LOW)

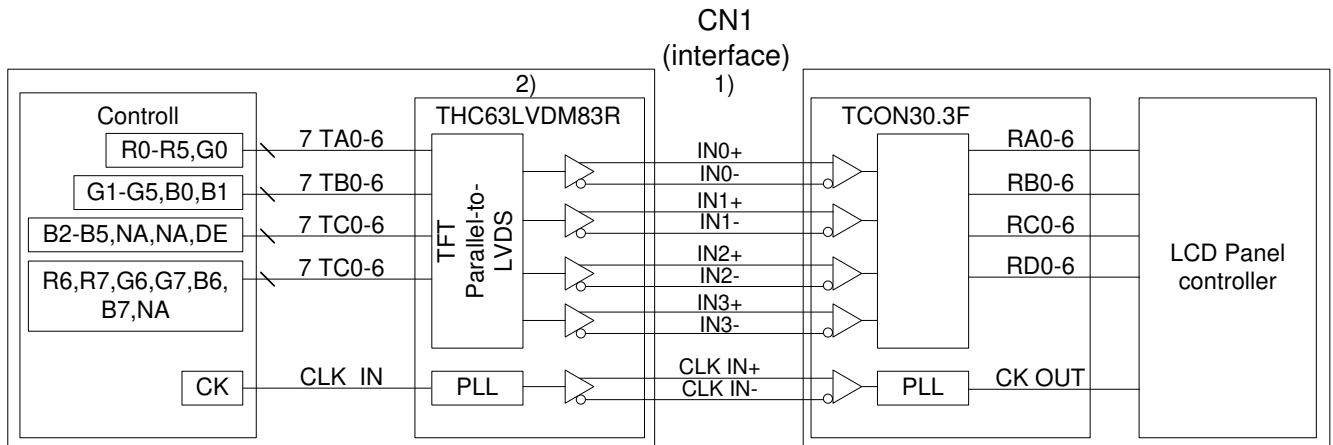

2) 8Bit / 6Bit Mode(AMODE = HIGH)

① 8Bit Mode

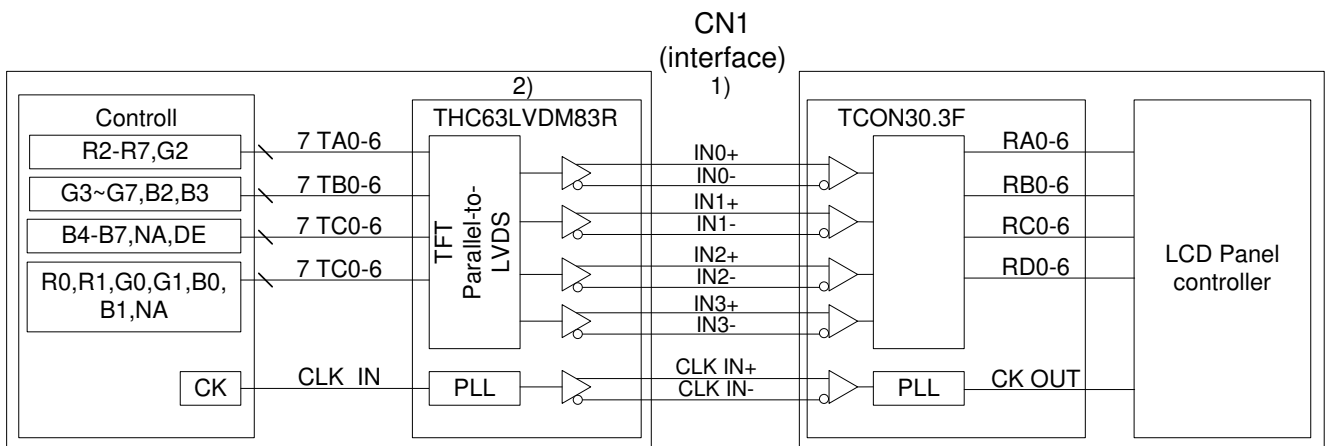

② 6Bit Mode

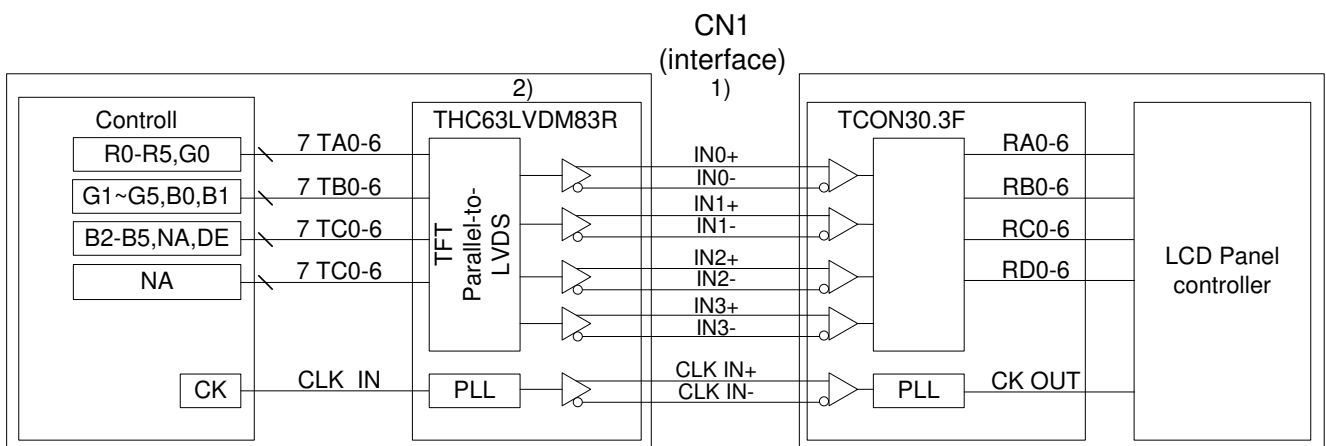

Note 1: 100Ω impedance of LVDS cable is recommended for best optical performance.

Note 2: Transmitter Made by Thine : THC63LVDM83R or equivalent.

9.3 DATA MAPPING

Transmitter		8Bit Mode	8Bit Mode	6Bit Mode
Pin No.	Pin name	AMODE		
		LOW	HIGH	
51	TA0	R0(LSB)	R2	R0(LSB)
52	TA1	R1	R3	R1
54	TA2	R2	R4	R2
55	TA3	R3	R5	R3
56	TA4	R4	R6	R4
3	TA5	R5	R7(MSB)	R5(MSB)
4	TA6	G0(LSB)	G2	G0(LSB)
6	TB0	G1	G3	G1
7	TB1	G2	G4	G2
11	TB2	G3	G5	G3
12	TB3	G4	G6	G4
14	TB4	G5	G7(MSB)	G5(MSB)
15	TB5	B0(LSB)	B2	B0(LSB)
19	TB6	B1	B3	B1
20	TC0	B2	B4	B2
22	TC1	B3	B5	B3
23	TC2	B4	B6	B4
24	TC3	B5	B7(MSB)	B5(MSB)
27	TC4	(NA)	(NA)	(NA)
28	TC5	(NA)	(NA)	(NA)
30	TC6	DE	DE	DE
50	TD0	R6	R0(LSB)	(NA)
2	TD1	R7(MSB)	R1	(NA)
8	TD2	G6	G0(LSB)	(NA)
10	TD3	G7(MSB)	G1	(NA)
16	TD4	B6	B0(LSB)	(NA)
18	TD5	B7(MSB)	B1	(NA)
25	TD6	(NA)	(NA)	(NA)

(1) 8Bit Mode (Amode=Low)

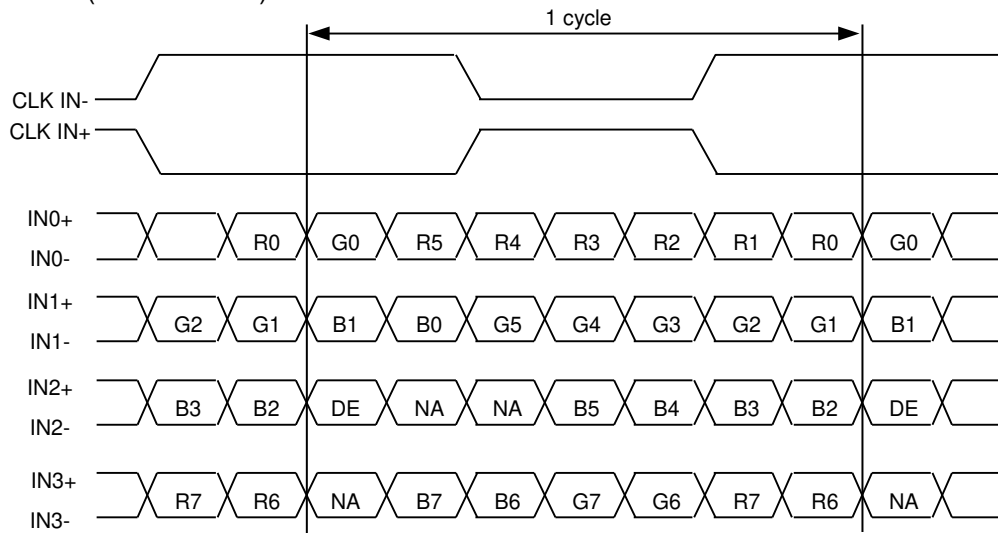

(2) 8Bit Mode (Amode=High)

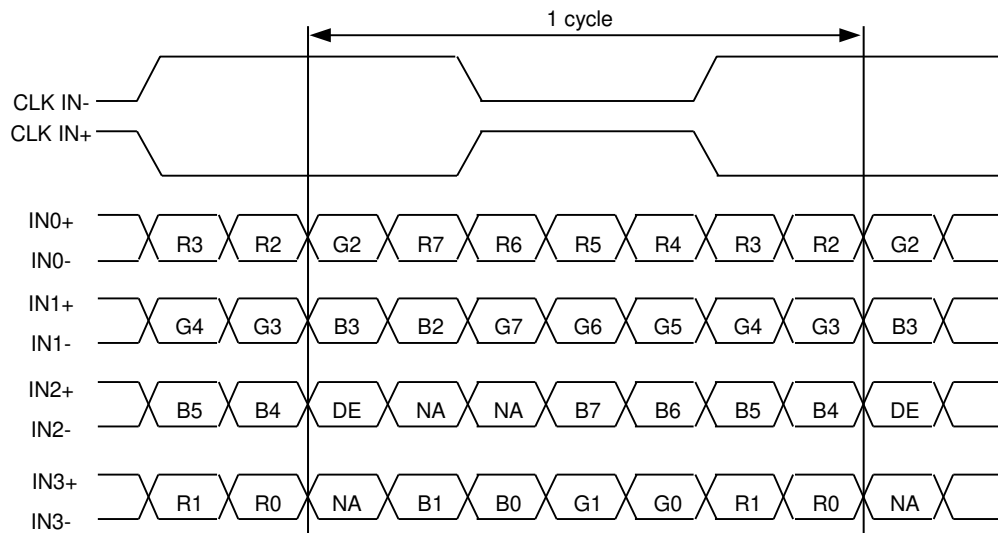

(3) 6Bit Mode (Amode=High)

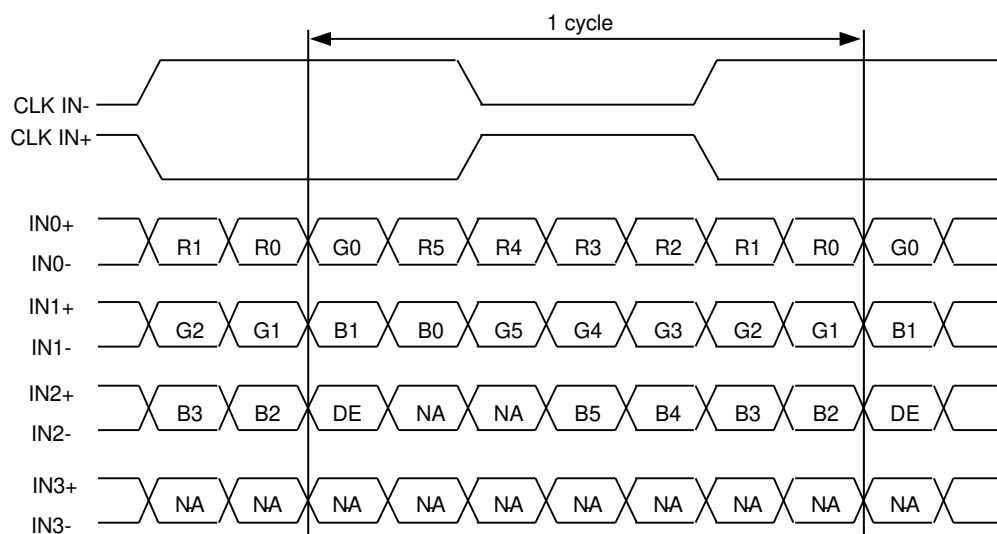

DE : Display Enable

NA : Not Available

9.4 DATA INPUT for DISPLAY COLOR

(8BIT MODE)

Input color		Red Data								Green Data								Blue Data							
		R7	R6	R5	R4	R3	R2	R1	R0	G7	G6	G5	G4	G3	G2	G1	G0	B7	B6	B5	B4	B3	B2	B1	B0
		MSB							LSB	MSB							LSB	MSB							LSB
Basic Color	Black	0	0	0	0	0	0	0	0	0	0	0	0	0	0	0	0	0	0	0	0	0	0	0	
	Red(255)	1	1	1	1	1	1	1	1	0	0	0	0	0	0	0	0	0	0	0	0	0	0	0	
	Green(255)	0	0	0	0	0	0	0	0	1	1	1	1	1	1	1	1	0	0	0	0	0	0	0	
	Blue(255)	0	0	0	0	0	0	0	0	0	0	0	0	0	0	0	1	1	1	1	1	1	1	1	
	Cyan	0	0	0	0	0	0	0	0	1	1	1	1	1	1	1	1	1	1	1	1	1	1	1	
	Magenta	1	1	1	1	1	1	1	1	0	0	0	0	0	0	0	1	1	1	1	1	1	1	1	
	Yellow	1	1	1	1	1	1	1	1	1	1	1	1	1	1	1	0	0	0	0	0	0	0	0	
	White	1	1	1	1	1	1	1	1	1	1	1	1	1	1	1	1	1	1	1	1	1	1	1	
Red	Black	0	0	0	0	0	0	0	0	0	0	0	0	0	0	0	0	0	0	0	0	0	0		
	Red(1)	0	0	0	0	0	0	0	1	0	0	0	0	0	0	0	0	0	0	0	0	0	0		
	Red(2)	0	0	0	0	0	0	1	0	0	0	0	0	0	0	0	0	0	0	0	0	0	0		
	:	:	:	:	:	:	:	:	:	:	:	:	:	:	:	:	:	:	:	:	:	:	:		
	Red(253)	1	1	1	1	1	1	0	1	0	0	0	0	0	0	0	0	0	0	0	0	0	0		
	Red(254)	1	1	1	1	1	1	1	0	0	0	0	0	0	0	0	0	0	0	0	0	0	0		
	Red(255)	1	1	1	1	1	1	1	1	0	0	0	0	0	0	0	0	0	0	0	0	0	0		
Green	Black	0	0	0	0	0	0	0	0	0	0	0	0	0	0	0	0	0	0	0	0	0	0		
	Green(1)	0	0	0	0	0	0	0	0	0	0	0	0	0	0	1	0	0	0	0	0	0	0		
	Green(2)	0	0	0	0	0	0	0	0	0	0	0	0	0	1	0	0	0	0	0	0	0	0		
	:	:	:	:	:	:	:	:	:	:	:	:	:	:	:	:	:	:	:	:	:	:	:		
	Green(253)	0	0	0	0	0	0	0	0	1	1	1	1	1	1	0	1	0	0	0	0	0	0		
	Green(254)	0	0	0	0	0	0	0	0	1	1	1	1	1	1	0	0	0	0	0	0	0	0		
	Green(255)	0	0	0	0	0	0	0	0	1	1	1	1	1	1	1	0	0	0	0	0	0	0		
Blue	Black	0	0	0	0	0	0	0	0	0	0	0	0	0	0	0	0	0	0	0	0	0	0		
	Blue(1)	0	0	0	0	0	0	0	0	0	0	0	0	0	0	0	0	0	0	0	0	0	1		
	Blue(2)	0	0	0	0	0	0	0	0	0	0	0	0	0	0	0	0	0	0	0	0	1	0		
	:	:	:	:	:	:	:	:	:	:	:	:	:	:	:	:	:	:	:	:	:	:	:		
	Blue(253)	0	0	0	0	0	0	0	0	0	0	0	0	0	0	0	1	1	1	1	1	1	0		
	Blue(254)	0	0	0	0	0	0	0	0	0	0	0	0	0	0	0	1	1	1	1	1	1	0		
	Blue(255)	0	0	0	0	0	0	0	0	0	0	0	0	0	0	0	1	1	1	1	1	1	1		

Note 1: Definition of gray scale : Color(n) Number in parenthesis indicates gray scale level. Larger number corresponds to brighter level.

Note 2: Data Signal : 1 : High, 0 : Low

(6 BIT MODE)

Input		Red Data						Green Data						Blue Data					
		R5	R4	R3	R2	R1	R0	G5	G4	G3	G2	G1	G0	B5	B4	B3	B2	B1	B0
		MSB			LSB			MSB			LSB			MSB			LSB		
Basic Color	Black	0	0	0	0	0	0	0	0	0	0	0	0	0	0	0	0	0	0
	Red(63)	1	1	1	1	1	1	0	0	0	0	0	0	0	0	0	0	0	0
	Green(63)	0	0	0	0	0	0	1	1	1	1	1	1	0	0	0	0	0	0
	Blue(63)	0	0	0	0	0	0	0	0	0	0	0	0	1	1	1	1	1	1
	Cyan	0	0	0	0	0	0	1	1	1	1	1	1	1	1	1	1	1	1
	Magenta	1	1	1	1	1	1	0	0	0	0	0	0	1	1	1	1	1	1
	Yellow	1	1	1	1	1	1	1	1	1	1	1	1	0	0	0	0	0	0
	White	1	1	1	1	1	1	1	1	1	1	1	1	1	1	1	1	1	1
Red	Black	0	0	0	0	0	0	0	0	0	0	0	0	0	0	0	0	0	0
	Red(1)	0	0	0	0	0	1	0	0	0	0	0	0	0	0	0	0	0	0
	Red(2)	0	0	0	0	1	0	0	0	0	0	0	0	0	0	0	0	0	0
	:	:	:	:	:	:	:	:	:	:	:	:	:	:	:	:	:	:	:
	Red(61)	1	1	1	1	0	1	0	0	0	0	0	0	0	0	0	0	0	0
	Red(62)	1	1	1	1	1	0	0	0	0	0	0	0	0	0	0	0	0	0
	Red(63)	1	1	1	1	1	1	0	0	0	0	0	0	0	0	0	0	0	0
Green	Black	0	0	0	0	0	0	0	0	0	0	0	0	0	0	0	0	0	0
	Green(1)	0	0	0	0	0	0	0	0	0	0	0	1	0	0	0	0	0	0
	Green(2)	0	0	0	0	0	0	0	0	0	0	0	1	0	0	0	0	0	0
	:	:	:	:	:	:	:	:	:	:	:	:	:	:	:	:	:	:	:
	Green(61)	0	0	0	0	0	0	1	1	1	1	0	1	0	0	0	0	0	0
	Green(62)	0	0	0	0	0	0	1	1	1	1	1	0	0	0	0	0	0	0
	Green(63)	0	0	0	0	0	0	1	1	1	1	1	1	0	0	0	0	0	0
Blue	Black	0	0	0	0	0	0	0	0	0	0	0	0	0	0	0	0	0	0
	Blue(1)	0	0	0	0	0	0	0	0	0	0	0	0	0	0	0	0	0	1
	Blue(2)	0	0	0	0	0	0	0	0	0	0	0	0	0	0	0	0	1	0
	:	:	:	:	:	:	:	:	:	:	:	:	:	:	:	:	:	:	:
	Blue(61)	0	0	0	0	0	0	0	0	0	0	0	0	1	1	1	1	0	1
	Blue(62)	0	0	0	0	0	0	0	0	0	0	0	0	1	1	1	1	1	0
	Blue(63)	0	0	0	0	0	0	0	0	0	0	0	0	1	1	1	1	1	1

Note 1: Definition of gray scale : Color(n) Number in parenthesis indicates gray scale level. Larger number corresponds to brighter level.

Note 2: Data Signal : 1 : High, 0 : Low

9.5 INTERFACE TIMING

(1) LVDS Receiver Timing

(Interface of TFT module)

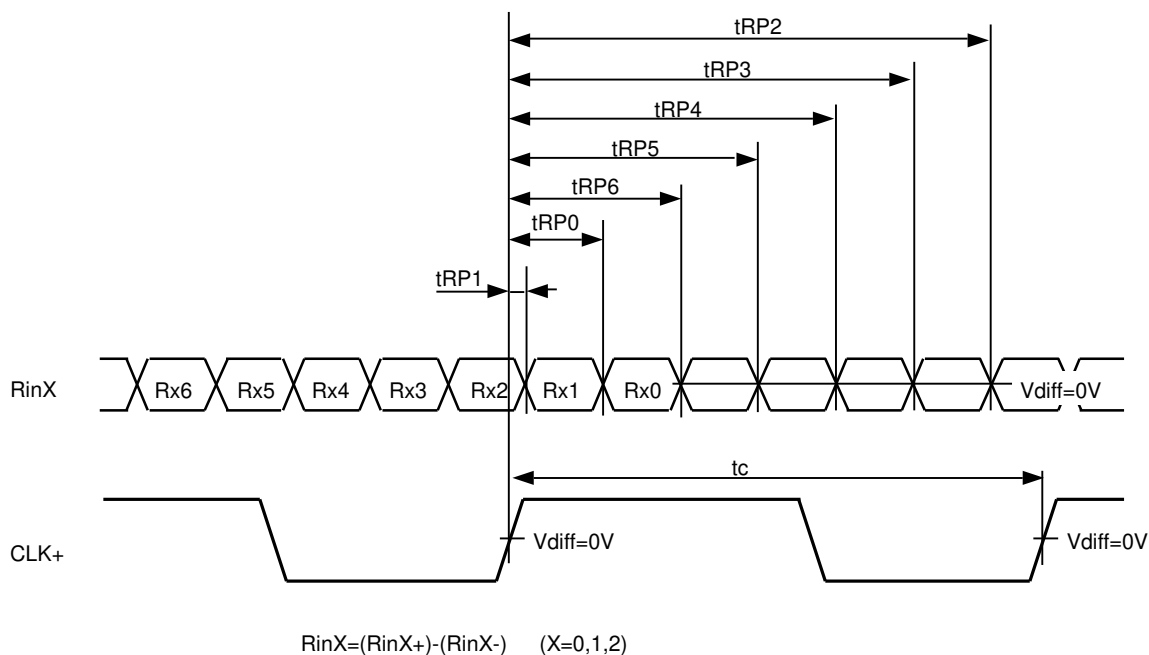

Item	Symbol	Min.	Typ.	Max.	Unit	
DCLK	FREQUENCY	$1/tc$	25.0	28.0 1) 33.3 2)	35.0	MHz
RinX (X=0,1,2)	0 data position	t_{RP0}	$1/7t_{CLK}-0.65$	$1/7*t_{CLK}$	$1/7t_{CLK}+0.65$	ns
	1st data position	t_{RP1}	-0.65	0	-0.65	
	2nd data position	t_{RP2}	$6/7t_{CLK}-0.65$	$6/7*t_{CLK}$	$6/7t_{CLK}+0.65$	
	3rd data position	t_{RP3}	$5/7t_{CLK}-0.65$	$5/7*t_{CLK}$	$5/7t_{CLK}+0.65$	
	4th data position	t_{RP4}	$4/7t_{CLK}-0.65$	$4/7*t_{CLK}$	$4/7t_{CLK}+0.65$	
	5th data position	t_{RP5}	$3/7t_{CLK}-0.65$	$3/7*t_{CLK}$	$3/7t_{CLK}+0.65$	
	6th data position	t_{RP6}	$2/7t_{CLK}-0.65$	$2/7*t_{CLK}$	$2/7t_{CLK}+0.65$	

Note 1: $f_{Frame}=50Hz$

Note 2: $f_{Frame}=60Hz$

(2) Timing converter timing

(Input timing for transmitter)

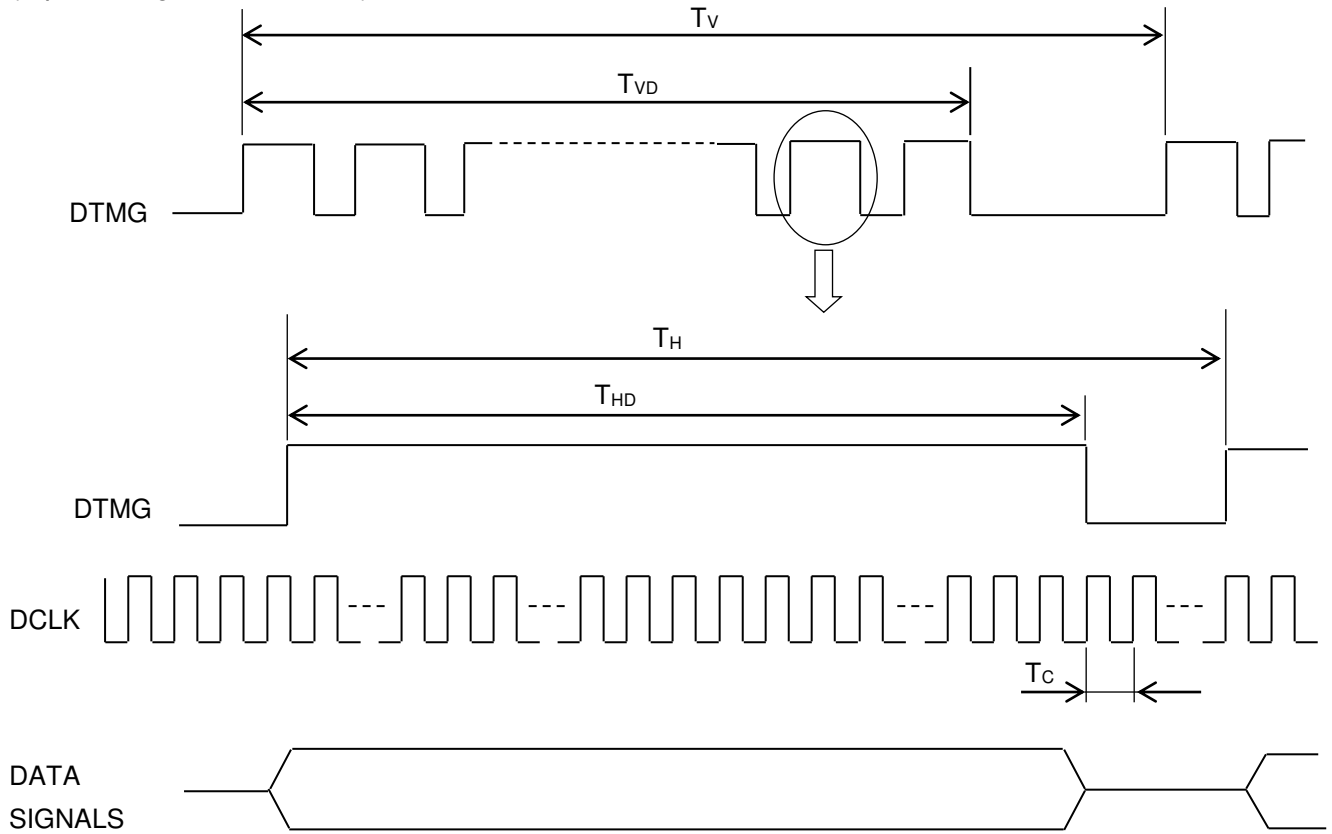

The timings except mentioned above are referred to the specifications of your transmitter.

Item		Symbol	Min.	Typ.	Max.	Unit	Remarks
DCLK	Cycle time	T_C	28.6	30.0	40.0	ns	
	Duty	D	0.45	0.5	0.55	-	
Horizontal	Horizontal period	T_H	845	1056	1500	T_C	
	Horizontal width-Active	T_{HD}	800	800	800	T_C	
Vertical	Vertical period	T_V	483	525	640	T_H	
	Vertical width-Active	T_{VD}	480	480	480	T_H	
	Frame frequency	f_v	42	60	75	Hz	

(3) Timing between interface signal and power supply

Power Supply, Input Signal and Backlight Voltage should comply with the following sequence.

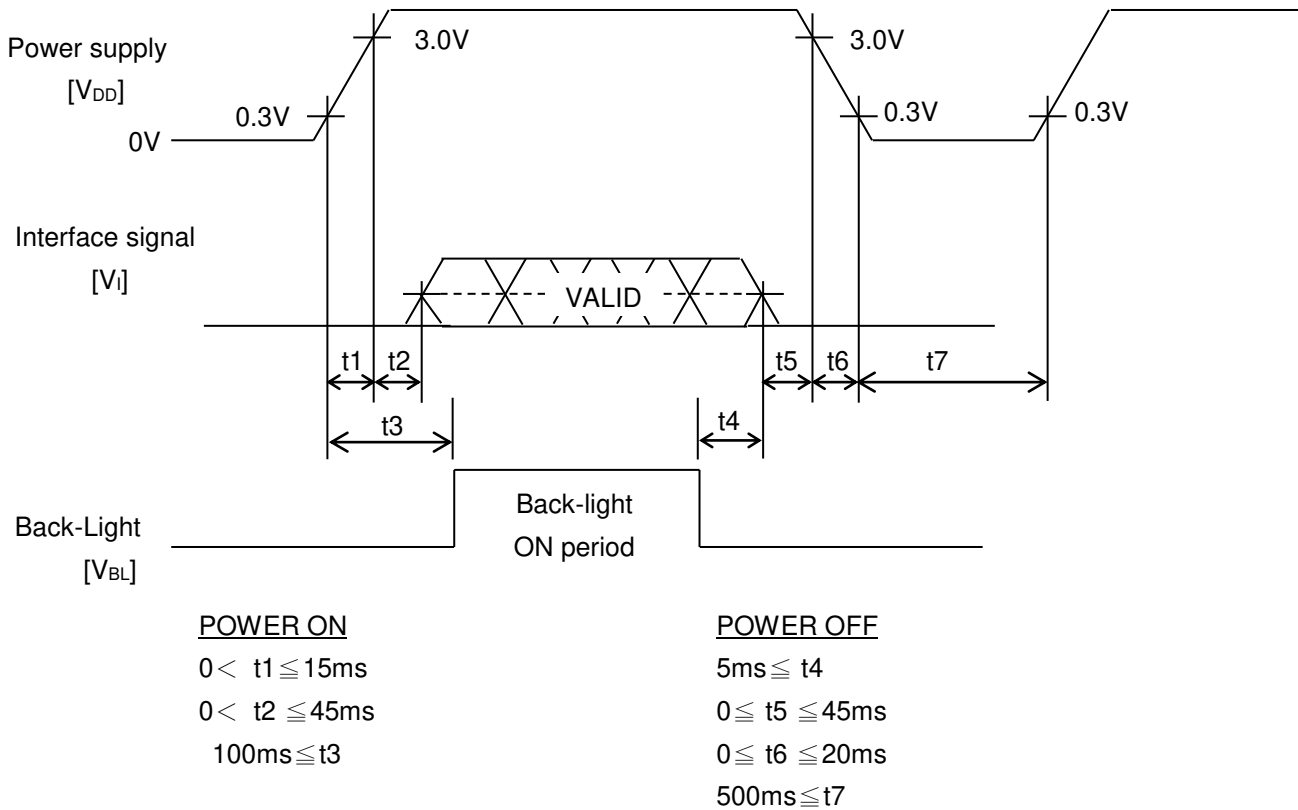

- Note 1: In order to prevent electronic parts from destruction caused by latch-up, please input signal after power supply voltage on. in addition, please turn off signals before power supply voltage off.
- Note 2: In order to prevent from function error due to residual charge, please reenter power supply voltage after time stipulated with t7.
- Note 3: Please turn on backlight after signals fix and turn off before signals down, otherwise noise appears in the display. The noise cause no problem with display performance in case of timing sequence comply with the spec.

10. OUTLINE DIMENSIONS

10.1 FRONT VIEW

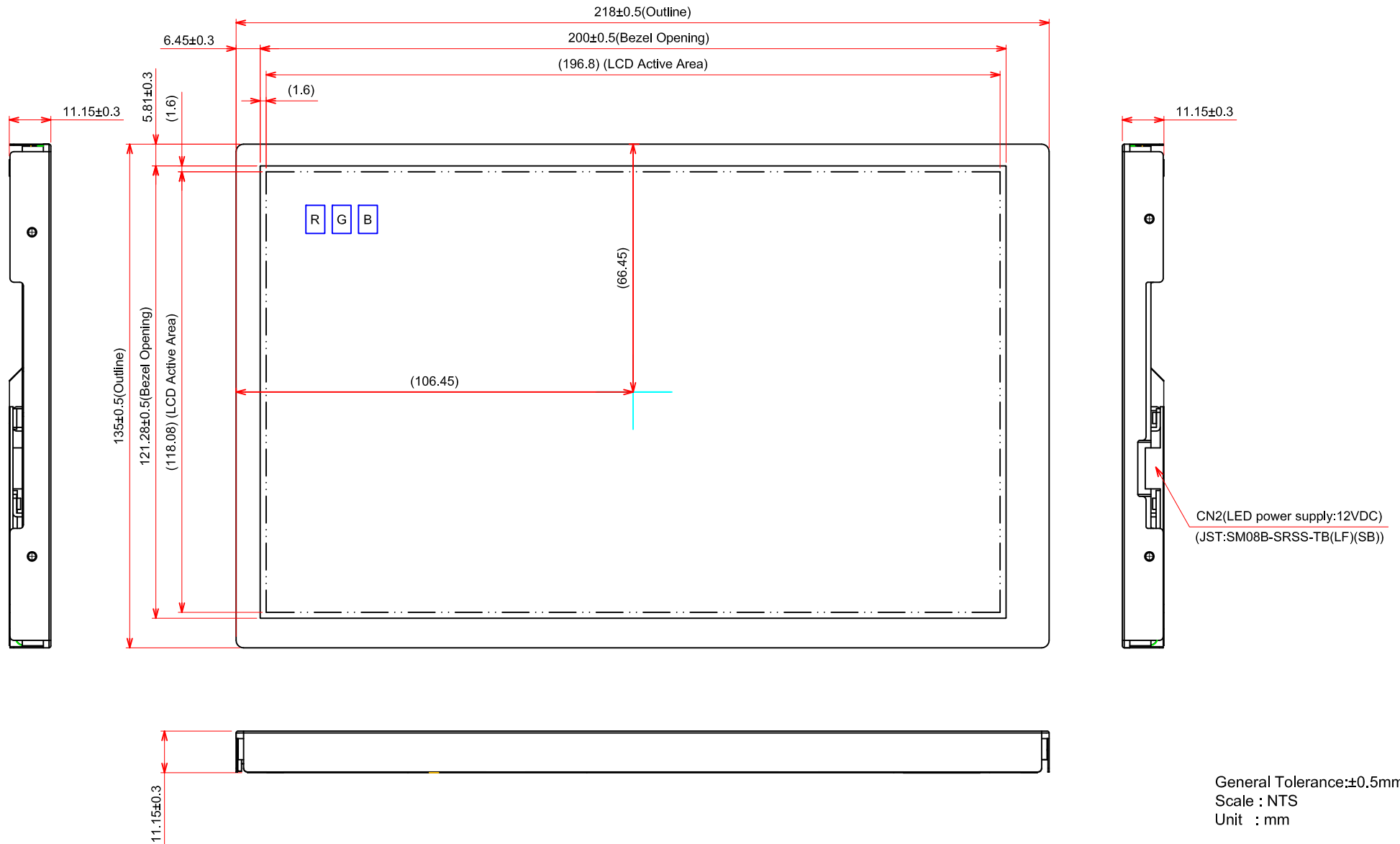

10.2 RAER VIEW

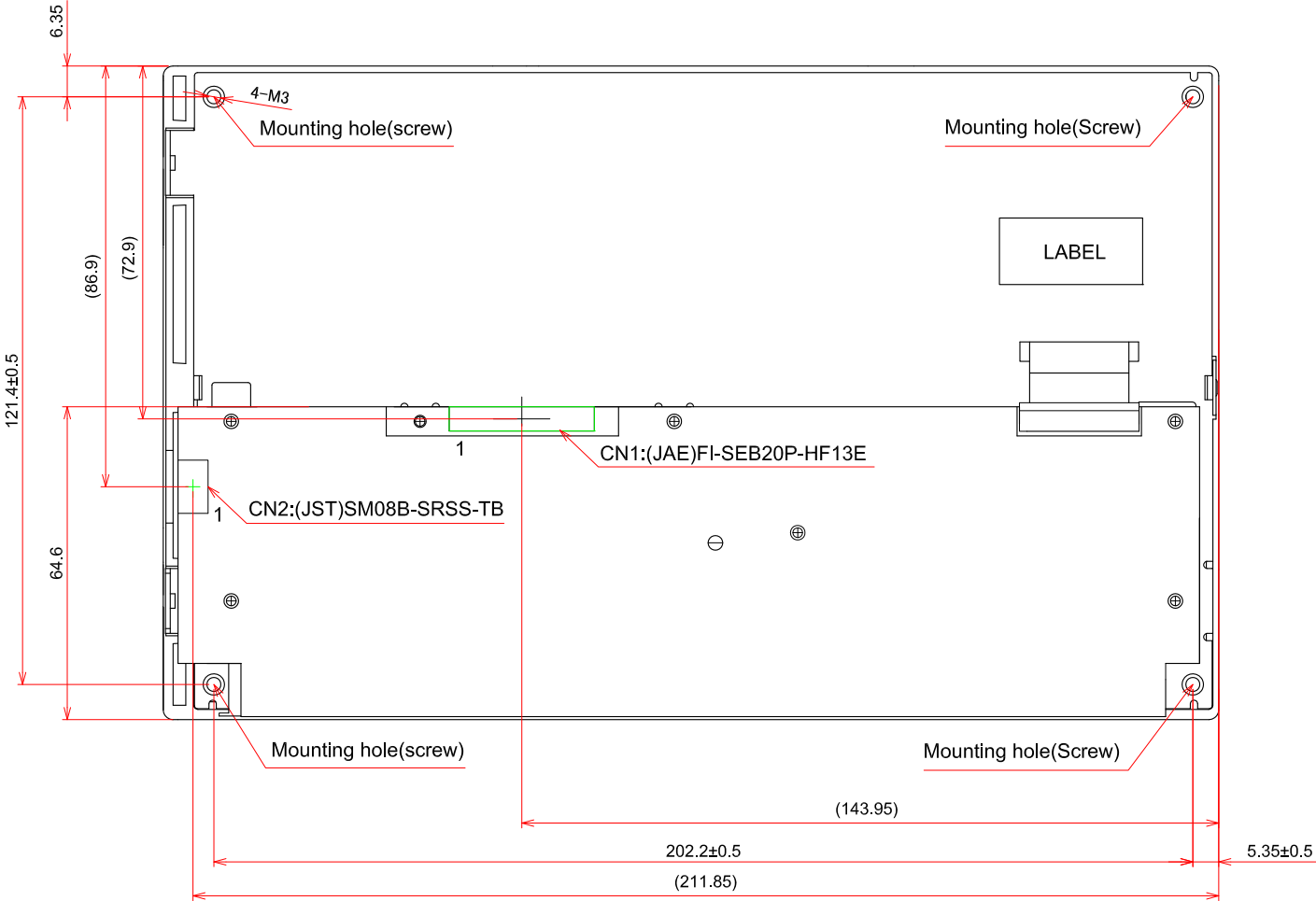

Note 1: Maximum length of screw for the mounting hole is 3.3mm

General Tolerance: ± 0.5 mm
 Scale : NTS
 Unit : mm

11. APPEARANCE STANDARD

The appearance inspection is performed in a dark room around 500~1000 lx based on the conditions as below:

- The distance between inspector's eyes and display is 30 cm.
- The viewing zone is defined with angle θ shown in Fig. 11.1 The inspection should be performed within 45° when display is shut down. The inspection should be performed within 5° when display is power on.

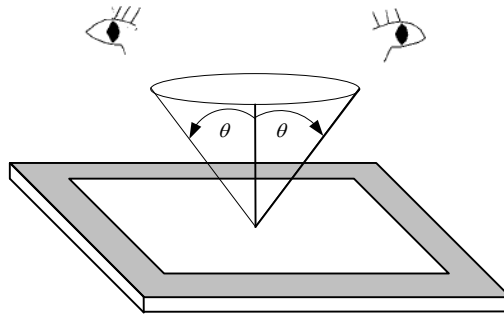

Fig. 11.1

11.1 THE DEFINITION OF LCD ZONE

LCD panel is divided into 3 areas as shown in Fig.11.2 for appearance specification in next section. A zone is the LCD active area (dot area); B zone is the area, which extended 1 mm out from LCD active area; C zone is the area between B zone and metal frame.

In terms of housing design, B zone is the recommended window area customers' housing should be located in.

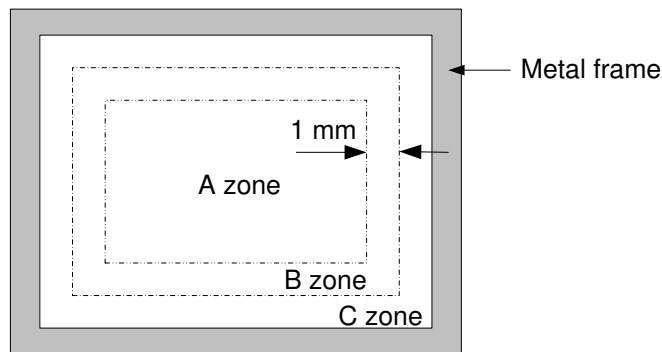

Fig. 11.2

11.2 LCD APPEARANCE SPECIFICATION

The specification as below is defined as the amount of unexpected phenomenon or material in different zones of LCD panel. The definitions of length, width and average diameter using in the table are shown in Fig. 11.3 and Fig. 11.4.

Item	Criteria				Applied zone
	Length (mm)	Width (mm)	Maximum number	Minimum space	
Scratches	Ignored	$W \leq 0.01$	Ignored	-	A, B
	$L \leq 40$	$0.01 < W \leq 0.02$	10	-	
	$L \leq 20$	$0.02 < W \leq 0.04$	10	-	
	-	$W > 0.04$	0		
	Average diameter (mm)		Maximum number		
	$D \leq 0.2$		Ignored		
	$0.2 < D \leq 0.4$		10		
	$D > 0.4$		0		
	Dent	Serious one is not allowed			
Wrinkles in polarizer	Serious one is not allowed				A
Bubbles on polarizer	Average diameter (mm)		Maximum number		A
	$D \leq 0.3$		Ignored		
	$0.3 < D \leq 0.5$		10		
	$0.5 < D \leq 1.0$		5		
	$D > 1.0$		0		
1) Stains 2) Foreign Materials 3) Dark Spot	Filamentous (Line shape)				A, B
	Length (mm)	Width (mm)	Maximum number		
	Ignored	$W \leq 0.02$	Ignored		
	$L \leq 2.0$	$0.02 < W \leq 0.03$	10		
	$L \leq 1.0$	$0.03 < W \leq 0.06$	10		
	-	$W > 0.06$	0		
	Round (Dot shape)				A, B
	Average diameter (mm)		Maximum number		
	$D \leq 0.2$		Ignored		
	$0.2 < D \leq 0.35$		5		
	$D > 0.35$		0		
	Those wiped out easily are acceptable				
	Dot-Defect (Note 1)			Type	Maximum number
Bright dot-defect		1 dot	0		
Dark dot-defect		1 dot	3		
		2 adjacent dot	2		
		3 adjacent dot or above	Not allowed		
		In total	5		
In total		5			

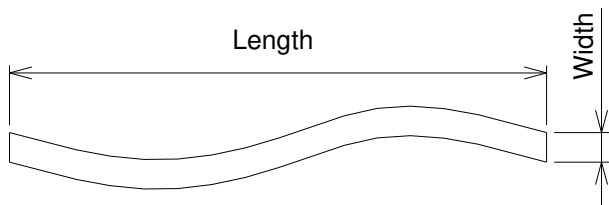

Fig 11.3

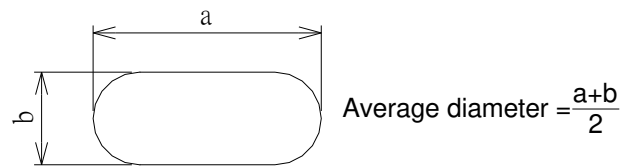

Fig 11.4

Note 1: The definitions of dot defect are as below:

- For bright dot-defect, showing black pattern, visible with 5% ND filter is defined.
- For dark dot-defect, showing white pattern, defect size over 1/2 dot area is defined.
- The definition of 1-dot-defect is the defect-dot, which is isolated and no adjacent defect-dot.
- The definition of adjacent dot is shown as Fig. 11.5.
- The Density of dot defect is defined in the area within diameter $\phi = 10\text{mm}$.

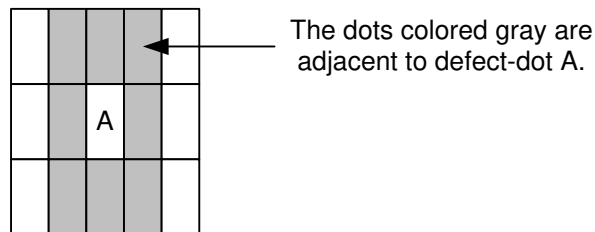

Fig. 11.5

12. PRECAUTIONS

12.1 PRECAUTIONS of ESD

- 1) Before handling the display, please ensure your body has been connected to ground to avoid any damages by ESD. Also, do not touch display's interface directly when assembling.
- 2) Please remove the protection film very slowly before turning on the display to avoid generating ESD.

12.2 PRECAUTIONS of HANDLING

- 1) In order to keep the appearance of display in good condition, please do not rub any surfaces of the displays by sharp tools harder than 3H, especially touch panel, metal frame and polarizer.
- 2) Please do not pile the displays in order to avoid any scars leaving on the display. In order to avoid any injuries, please pay more attention for the edges of glasses and metal frame, and wear finger cots to protect yourself and the display before working on it.
- 3) Touching the display area or the terminal pins with bare hand is prohibited. This is because it will stain the display area and cause poor insulation between terminal pins, and might affect display's electrical characteristics furthermore.
- 4) Do not use any harmful chemicals such as acetone, toluene, and isopropyl alcohol to clean display's surfaces.
- 5) Please use soft cloth or absorbent cotton with ethanol to clean the display by gently wiping. Moreover, when wiping the display, please wipe it by horizontal or vertical direction instead of circling to prevent leaving scars on the display's surface, especially polarizer.
- 6) Please wipe any unknown liquids immediately such as saliva, water or dew on the display to avoid color fading or any permanently damages.
- 7) Maximum pressure to the surface of the display must be less than 1.96×10^4 Pa. If the area of adding pressure is less than 1 cm^2 , the maximum pressure must be less than 1.96N.

12.3 PRECAUTIONS OF OPERATING

- 1) Please input signals and voltages to the displays according to the values defined in the section of electrical characteristics to obtain the best performance. Any voltages over than absolute maximum rating will cause permanent damages to this display. Also, any timing of the signals out of this specification would cause unexpected performance.
- 2) When the display is operating at significant low temperature, the response time will be slower than it at 25°C . In high temperature, the color will be slightly dark and blue compared to original pattern. However, these are temperature-related phenomenon of LCD and it will not cause permanent damages to the display when used within the operating temperature.
- 3) The use of screen saver or sleep mode is recommended when static images are likely for long periods of time. This is to avoid the possibility of image sticking.
- 4) Spike noise can cause malfunction of the circuit. The recommended limitation of spike noise is no bigger than $\pm 100 \text{ mV}$.

12.4 PRECAUTIONS of STORAGE

If the displays are going to be stored for years, please be aware the following notices.

- 1) Please store the displays in a dark room to avoid any damages from sunlight and other sources of UV light.
- 2) The recommended long term storage temperature is between 10 C° ~35 C° and 55%~75% humidity to avoid causing bubbles between polarizer and LCD glasses, and polarizer peeling from LCD glasses.
- 3) It would be better to keep the displays in the container, which is shipped from KOE, and do not unpack it.
- 4) Please do not stick any labels on the display surface for a long time, especially on the polarizer.

13. DESIGNATION of LOT MARK

1) The lot mark is showing in Fig.13.1. First 4 digits are used to represent production lot, T represented made in Taiwan, and the last 6 digits are the serial number.

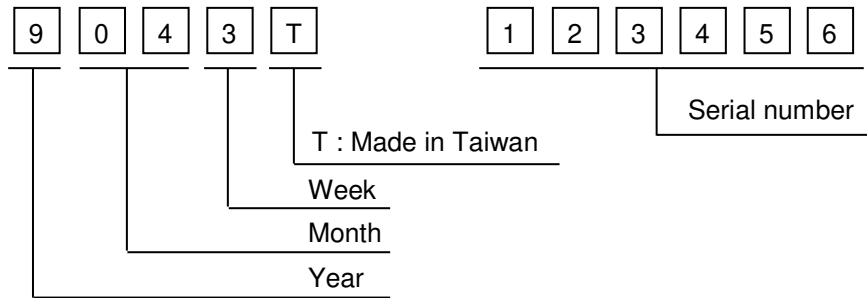

2) The tables as below are showing what the first 4 digits of lot mark are shorted for.

Year	Mark
2019	9
2020	0
2021	1
2022	2
2023	3

Month	Mark	Month	Mark
1	01	7	07
2	02	8	08
3	03	9	09
4	04	10	10
5	05	11	11
6	06	12	12

Week (Days)	Mark
1~7	1
8~14	2
15~21	3
22~28	4
29~31	5

3) Except letters I and O, revision number will be shown on lot mark and following letters A to Z.

4) The location of the lot mark is on the back of the display shown in Fig. 13.1.

Label example:

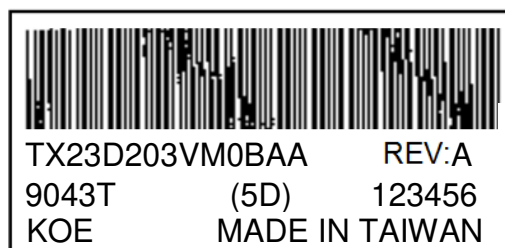

Fig 13.1