

KOE

JDI Group

Kaohsiung Opto-Electronics Inc.

FOR MESSRS : _____

DATE: Oct. 25th ,2019

CUSTOMER'S ACCEPTANCE SPECIFICATIONS

TX11D201VM0BAA

Contents

No.	ITEM	SHEET No.	PAGE
1	COVER	7B64PS 2701-TX11D201VM0BAA-2	1-1/1
2	RECORD OF REVISION	7B64PS 2702-TX11D201VM0BAA-2	2-1/1
3	GENERAL DATA	7B64PS 2703-TX11D201VM0BAA-2	3-1/1
4	ABSOLUTE MAXIMUM RATINGS	7B64PS 2704-TX11D201VM0BAA-2	4-1/1
5	ELECTRICAL CHARACTERISTICS	7B64PS 2705-TX11D201VM0BAA-2	5-1/2~2/2
6	OPTICAL CHARACTERISTICS	7B64PS 2706-TX11D201VM0BAA-2	6-1/2~2/2
7	BLOCK DIAGRAM	7B64PS 2707-TX11D201VM0BAA-2	7-1/1
8	RELIABILITY TESTS	7B64PS 2708-TX11D201VM0BAA-2	8-1/1
9	LCD INTERFACE	7B64PS 2709-TX11D201VM0BAA-2	9-1/9~9/9
10	OUTLINE DIMENSIONS	7B64PS 2710-TX11D201VM0BAA-2	10-1/1
11	APPEARANCE STANDARD	7B64PS 2711-TX11D201VM0BAA-2	11-1/5~5/5
12	PRECAUTIONS	7B64PS 2712-TX11D201VM0BAA-2	12-1/2~2/2
13	DESIGNATION OF LOT MARK	7B64PS 2713-TX11D201VM0BAA-2	13-1/1

ACCEPTED BY: _____

PROPOSED BY: Oblack Tsai

2. RECORD OF REVISION

DATE	SHEET No.	SUMMARY
Oct.25,'19	7B64PS2704- TX11D201VM0BAA-2 Page 4-1/1	4. ABSOLUTE MAXIMUM RATINGS Revised : Operating temperature (panel surface) Min. -30 ↓ Operating temperature (ambient temperature) Min. -40
	7B64PS2708- TX11D201VM0BAA-2 Page 8-1/1	8. RELIABILITY TESTS Revised : Low temperature Operating -30 deg.C, 500Hr ↓ Low temperature Operating -40 deg.C, 500Hr

3. GENERAL DATA

3.1 DISPLAY FEATURES

This module is a 4.2" WQVGA of 16:9 format amorphous silicon TFT. The pixel format is vertical stripe and sub pixels are arranged as R(red), G(green), B(blue) sequentially. This display is RoHS compliant, COG (chip on glass) technology and LED backlight are applied on this display.

Part Name	TX11D201VM0BAA
Module Dimensions	102.5(W) mm x 69.0(H) mm x 9.8 (D) mm
LCD Active Area	92.88(W) mm x 52.632(H) mm
Pixel Pitch	0.0645 x3(RGB) (W)mm x0.1935 (H) mm
Resolution	480x3(RGB)(W) x 272(H) dots
Color Pixel Arrangement	R, G, B Vertical stripe
LCD Type	Transmissive Color TFT; Normally Black
Polarizer surface	Antiglare / Antireflection, Hardness: 2H
Display Type	Active Matrix
Number of Colors	16.7M Colors (8-bit RGB)
Backlight	Light Emitting Diode(LED)
Weight	97g (typ.)
Interface	CMOS; 68 pins
Power Supply Voltage	3.3V for LCD; 13.5V for backlight.
Viewing Direction	Super Wide Version (In Plane Switching)

4. ABSOLUTE MAXIMUM RATINGS

Item	Symbol	Min.	Max.	Unit	Remarks
Input voltage	VB+	-0.3	23	V	-
+3.3V power supply voltage	VCC	-0.3	4.0	V	-
Input signal voltage 1	Vi1	-0.3	7.0	V	Note 1, 4
Input signal voltage 2	Vi2	-0.3	VCC+0.3	V	Note 2
Operating temperature (ambient temperature)	TOP	-40	85	deg.C	No dew condition Note 3
Storage Temperature	TST	-40	95		

Note 1: BL_PWM

Note 2: HD, DEN, VD, NCLK, R0-R7, G0-G7, B0-B7, HRV, VRV, PON

Note 3: Module temperature is apt to increase while it's driving due to the heat of backlight etc. Design carefully not to exceed +85deg.C at every point of LCD surface that should come to contact with any other equipment. In operation temperature range, only LCD operation is assured. Contrast, response time, or other LCD characteristics are specified in the condition of ambient temperature: Ta=+25deg.C.

Note 4: PWM dimming shall operate at $T_a \geq 75\text{deg.C}$ (See the following figure)

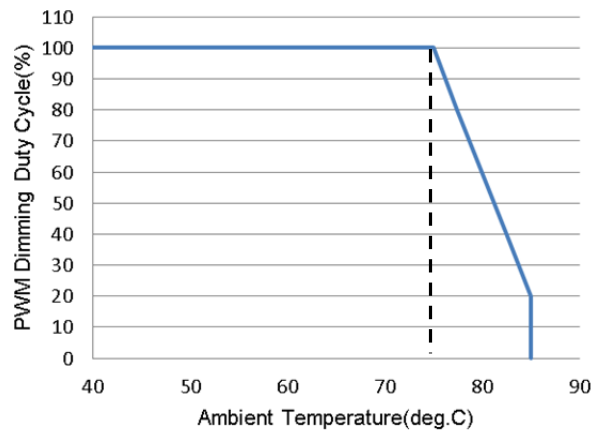

Ambient Temperature vs. PWM Dimming Duty Cycle
(Reference data as LCD module alone)

5. ELECTRICAL CHARACTERISTICS

5.1 LCD CHARACTERISTICS

$T_a = 25\text{ }^\circ\text{C}$, $V_{SS} = 0\text{V}$

Item	Symbol	Condition	Min.	Typ.	Max.	Unit	Remarks
Power Supply Voltage	VCC	-	3.0	3.3	3.6	V	-
Permissive Voltage Ripple	-	-	-	-	100	mVp-p	
Power Supply Current	ICC	VCC-VSS =3.3V	-	18	60	mA	Note 2
Input signal Voltage	VIH2	"H" level	0.7VCC	-	VCC	V	Note 1
	VIL2	"L" level	VSS	-	0.7		
Frame Frequency	f_{Frame}	-	50	50	60	Hz	-
CLK Frequency	f_{CLK}	-	9.34	9.70	11.19	MHz	

Note 1: The rating is defined for the signal voltages of the interface such as HD, DEN, VD, NCLK, R0-R7, G0-G7, B0-B7, HRV, VRV, PON.

Note 2: An all white pattern is used when measuring ICC, f_{Frame} is set to 50 Hz.

Note 3: 630mA fuse is applied in the module for ICC. For display activation and protection purpose, power supply is recommended larger than 1.6A to start the display and break fuse once any short circuit occurred.

5.2 BACKLIGHT CHARACTERISTICS

$T_a = 25^\circ\text{C}$

Item	Symbol	Condition	Min.	Typ.	Max.	Unit	Remarks
LED Input Voltage	VB+	IB+=120mA	7	13.5	18	V	Note 2
LED Forward Current (PWM Control)	IB+	100% duty	-	120	400	mA	Note 2
PWM Signal Voltage	VIH1	"H" level	2.1	3.3	5.5	V	Note 3
	VIL1	"L" level	VSS	-	0.4		
LED Lifetime	-	IB+=120mA	-	50K	-	hrs	Note 4

Note 1: Fig. 5.1 shows the LED backlight circuit.

Note.2: Dip of VB+

VB+ can accept +5.0V for 150ms (Backlight will not blinking.)

IB+(max) is 450mA when +5.0V is applied to VB+

Ta=25deg.C PWM=100%

VB+ changes shall not exceed the speed of 2VOLT / 100usec.

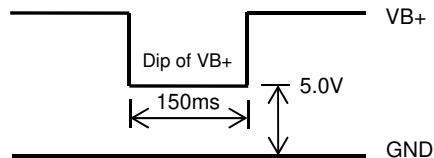

Note 3: Dimming function can be obtained by applying PWM signal from the display interface, The recommended PWM signal is 150 ~ 250 Hz.

Note 4: The estimated lifetime is specified as the time to reduce 50% brightness by applying 120mA at 25°C.

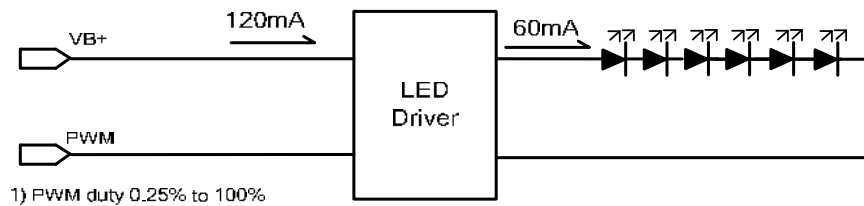

Fig 5.1

6. OPTICAL CHARACTERISTICS

The optical characteristics are measured based on the conditions as below:

- Supplying the signals and voltages defined in the section of electrical characteristics.
- The backlight unit needs to be turned on for 30 minutes.
- The ambient temperature is 25 °C .
- In the dark room around 100 lx, the equipment has been set for the measurements as shown in Fig 6.1.

$$T_a = 25 \text{ }^\circ\text{C}, f_{Frame} = 50\text{Hz}, VCC = 3.3\text{V}$$

Item	Symbol	Condition	Min.	Typ.	Max.	Unit	Remarks	
Brightness of White	-	IB+= 120mA $\phi = 0^\circ, \theta = 0^\circ$	560	750	-	cd/m ²	Note 1	
Brightness Uniformity	-		70	80	-	%	Note 2	
Contrast Ratio	CR		1000	1500	-	-	Note 3	
Response Time	Tr + Tf	$\phi = 0^\circ, \theta = 0^\circ$	-	25	-	ms	Note 4	
NTSC Ratio	-	$\phi = 0^\circ, \theta = 0^\circ$	-	65	-	%	-	
Viewing Angle	θ_x	$\phi = 0^\circ, CR \geq 10$	70	85	-	Degree	Note 5	
	$\theta_{x'}$	$\phi = 180^\circ, CR \geq 10$	70	85	-			
	θ_y	$\phi = 90^\circ, CR \geq 10$	70	85	-			
	$\theta_{y'}$	$\phi = 270^\circ, CR \geq 10$	70	85	-			
Color Chromaticity	Red	X	$\phi = 0^\circ, \theta = 0^\circ$	0.572	0.622	0.672	Note 6	Note 6
		Y		0.298	0.348	0.398		
	Green	X		0.257	0.307	0.357		
		Y		0.563	0.613	0.663		
	Blue	X		0.100	0.150	0.200		
		Y		0.040	0.090	0.140		
	White	X		0.240	0.290	0.340		
		Y		0.270	0.320	0.370		

Note 1: The brightness is measured from 9 point average value of the panel, P5 in Fig. 6.2, for the typical value.

Note 2: The brightness uniformity is calculated by the equation as below:

$$\text{Brightness uniformity} = \frac{\text{Min. Brightness}}{\text{Max. Brightness}} \times 100\%$$

which is based on the brightness values of the 9 points in active area measured by BM-5 as shown in Fig. 6.2.

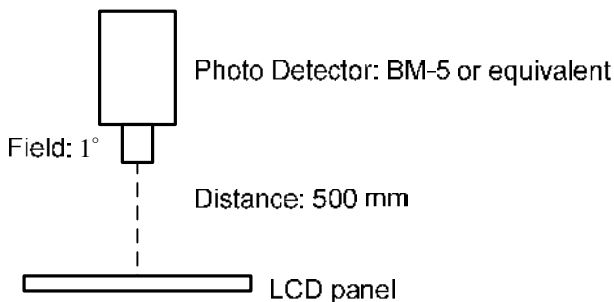

Fig 6.1

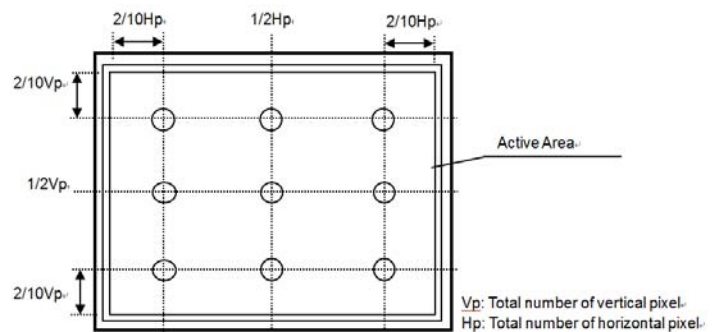

Fig 6.2

Note 3: The Contrast ratio is measured from the center point of the panel, P5, and defined as the following equation:

$$CR = \frac{\text{Brightness of White}}{\text{Brightness of Black}}$$

Note 4: The definition of response time is shown in Fig. 6.3. The rising time is the period from 10% brightness to 90% brightness when the data is from black to white. Oppositely, Falling time is the period from 90% brightness falling to 10% brightness.

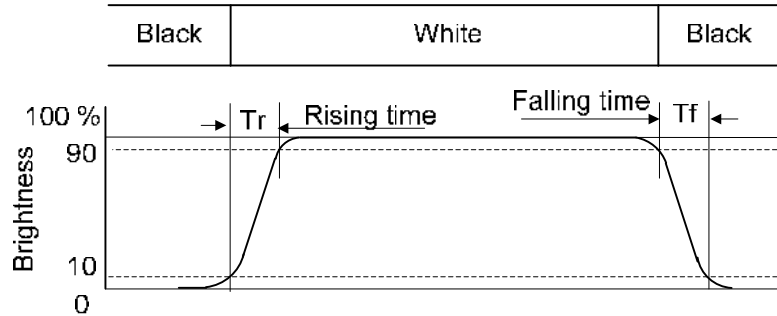

Fig 6.3

Note 5: The definition of viewing angle is shown in Fig. 6.4. Angle ϕ is used to represent viewing directions, for instance, $\phi = 270^\circ$ means 6 o'clock, and $\phi = 0^\circ$ means 3 o'clock. Moreover, angle θ is used to represent viewing angles from axis Z toward plane XY.

The display is super wide viewing angle version, so that the best optical performance can be obtained from every viewing direction.

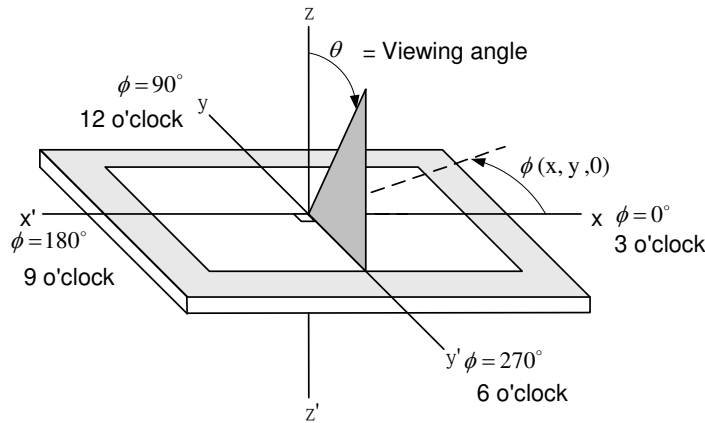
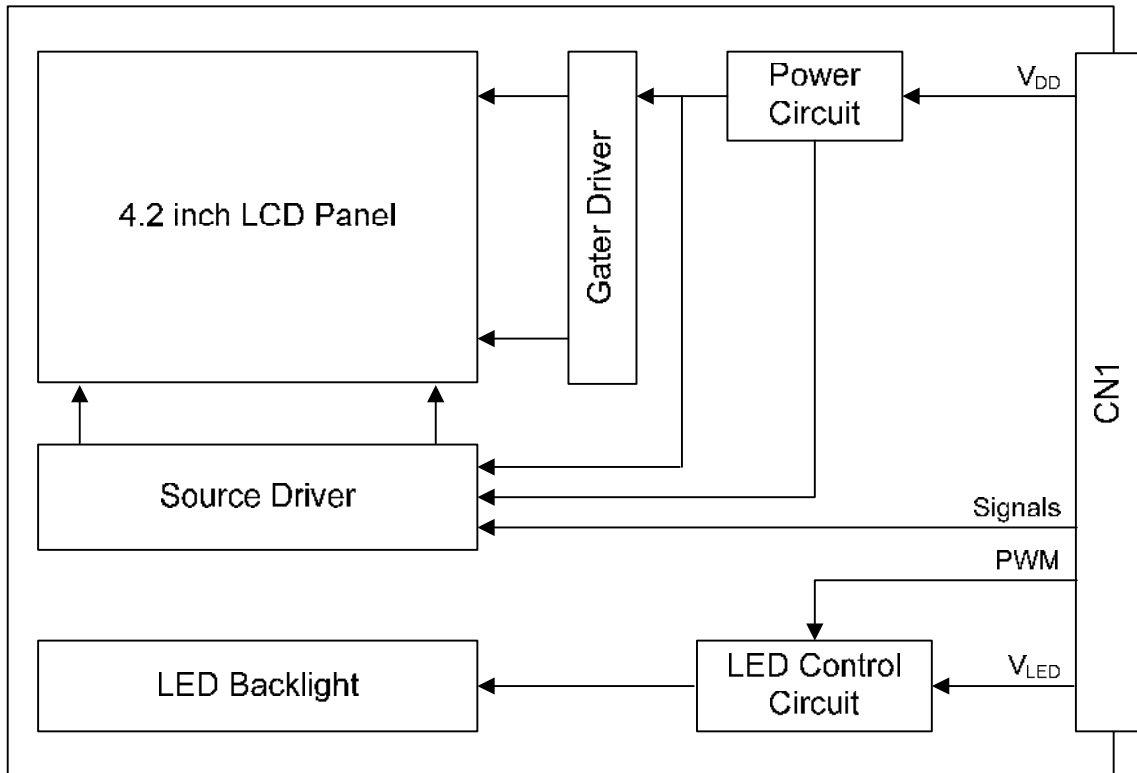

Fig 6.4

Note 6: The color chromaticity is measured from the center point of the panel, P5, as shown in Fig. 6.2.

7. BLOCK DIAGRAM



Note 1: Signals are a DEN, VD, HD, NCLK and RGB data bus.

8. RELIABILITY TESTS

8.1 STANDARD TEST ITEM and CONDITON / METHOD

Test item	Test condition	Confirm method / Judgment
Dry heat Operating	85 deg.C (surface temperature of polarizer), 500Hr	After 500 hours, product will be left in normal temperature and normal humidity for two hours. It should work without fail mechanically and electrically, and standard in 8.2 has to be met.
Low temperature Operating	-40 deg.C, 500Hr	
Dry heat Storage	90 deg.C, 500Hr	
Low temperature Storage	-40 deg.C, 500Hr	
High temperature High humidity Operating	60 deg.C, 90%RH, 500Hr	
Thermal shock	-40 deg.C(30min.) +85 deg.C(30min.),500 cycles	
Vibration (Non-operating)	Frequency: 8~33.3Hz · Amplitude 1.3mm. Frequency: 33.3~400Hz, Acceleration:3G, Cycle 15min. Direction of XZ: 2Hr, Direction of Y: 4Hr	Product should work without fail mechanically and electrically and standard in 8.2 has to be met.
Impact (Non-operating)	100G,6ms, half sin wave, ±XYZ One time for every direction.	Product should work without fail mechanically and electrically and standard in 8.2 has to be met.
ESD (Non-operating)	Contact Discharge 150pF, 330ohm, ±15k Panel center 3 times (intervals of 1s) Non-operating	No abnormality like abnormal display. Current consumption should be less than twice of initial value.
ESD (Non-operating)	Air Discharge 150pF, 330ohm, ±15k 4 points to metal frame 3 times for each, (intervals of 1s) Non-operating	No abnormality like abnormal display. Current consumption should be less than twice of initial value.

8.2 FAILURE JUDGMENT STANDARD

After reliability test, inspection is executed in the normal temperature / humidity environment

- 1) There should be no remarkable deterioration in display quality and appearance.
- 2) Contrast ratio should be over 50% of initial value.
- 3) Brightness should be over 50% of initial value.
- 4) There should be no abnormal function.
- 5) Current consumption should be less than twice of initial value.

9. LCD INTERFACE

9.1 INTERFACE PIN CONNECTIONS

The display interface connector is FH41-068S-0.5SH(0.5) made by HIROSE ELECTRIC and more details of the connector are shown in the section of outline dimension.

Pin assignment of LCD interface is as below:

Pin No.	Signal	Function	Pin No.	Signal	Function
1	TEST	Continuity to Pin 68	35	R0	(RGB I/F) Red Data (LSB)
2	GND	GND	36	GND	GND
3	GND	GND	37	GND	GND
4	GND	GND	38	G7	(RGB I/F) Green Data (MSB)
5	GND	GND	39	G6	(RGB I/F) Green Data
6	GND	GND	40	G5	(RGB I/F) Green Data
7	N.C	No connection	41	G4	(RGB I/F) Green Data
8	VB+	Power Supply Voltage for Backlight	42	G3	(RGB I/F) Green Data
9	VB+	Power Supply Voltage for Backlight	43	G2	(RGB I/F) Green Data
10	N.C	No connection	44	G1	(RGB I/F) Green Data
11	GND	GND	45	G0	(RGB I/F) Green Data (LSB)
12	GND	GND	46	GND	GND
13	N.C	No connection	47	GND	GND
14	BL_PWM	Input Signal for Backlight Dimming	48	B7	(RGB I/F) Blue Data (MSB)
15	N.C	No connection	49	B6	(RGB I/F) Blue Data
16	TEST	Test Pin	50	B5	(RGB I/F) Blue Data
17	TEST	Test Pin	51	B4	(RGB I/F) Blue Data
18	VRV	Vertical Scanning Direction	52	B3	(RGB I/F) Blue Data
19	HRV	Horizontal Scanning Direction	53	B2	(RGB I/F) Blue Data
20	GND	GND	54	B1	(RGB I/F) Blue Data
21	GND	GND	55	B0	(RGB I/F) Blue Data(LSB)
22	N.C	No connection	56	GND	GND
23	VCC	Power Supply Voltage	57	GND	GND
24	VCC	Power Supply Voltage	58	PON	Reset Signal
25	N.C	No connection	59	GND	GND
26	GND	GND	60	GND	GND
27	GND	GND	61	NCLK	Clock Signal
28	R7	(RGB I/F) Red Data (MSB)	62	GND	GND
29	R6	(RGB I/F) Red Data	63	GND	GND
30	R5	(RGB I/F) Red Data	64	VD	Vertical Sync
31	R4	(RGB I/F) Red Data	65	DEN	Horizontal Data Enable
32	R3	(RGB I/F) Red Data	66	HD	Horizontal Sync
33	R2	(RGB I/F) Red Data	67	GND	GND
34	R1	(RGB I/F) Red Data	68	TEST	Continuity to Pin 1

9.2 TIMING CHART

A. GENERAL TIMING DIAGRAM

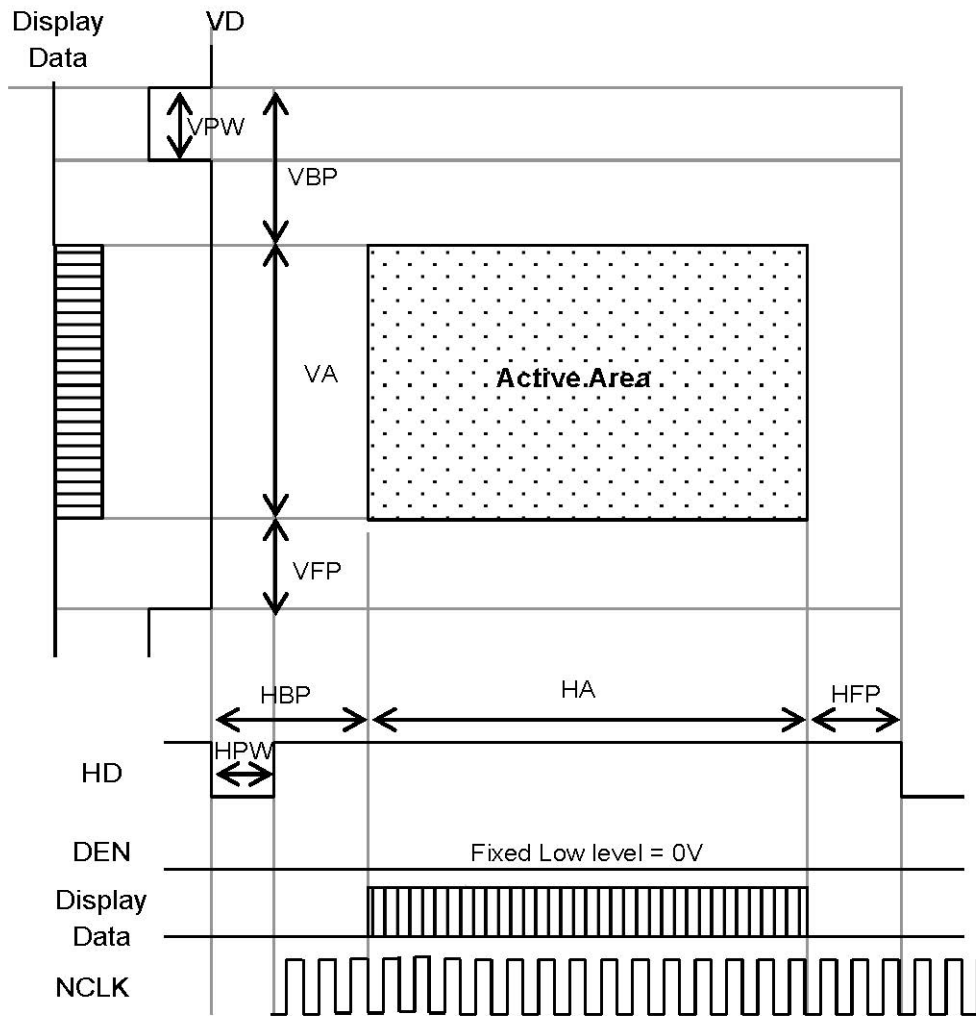

Condition	Description
VPW	Vertical Sync time (VD=L)
VBP	Vertical Back Porch
VA	Vertical Display Active Area
VFP	Vertical Front Porch
HPW	Horizontal Sync time (HD=L)
HBP	Horizontal Back Porch
HA	Horizontal Display Active Area
HFP	Horizontal Front Porch

B. TIMING CHART1 (HORIZONTAL)

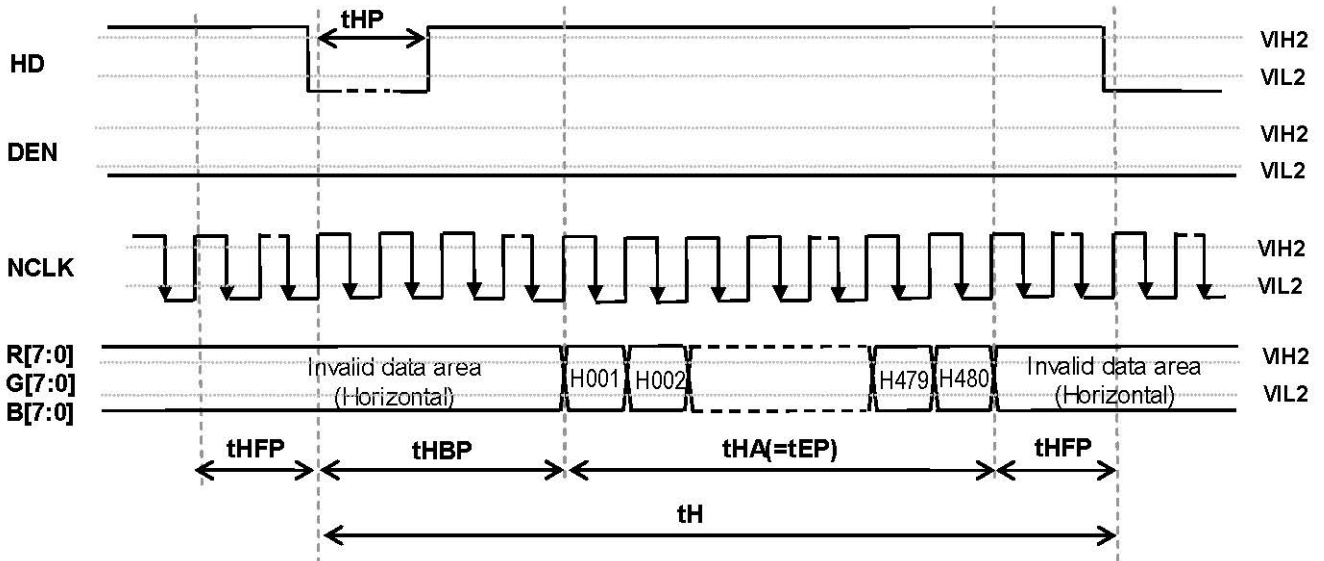

C. TIMING CHART2 (VERTICAL)

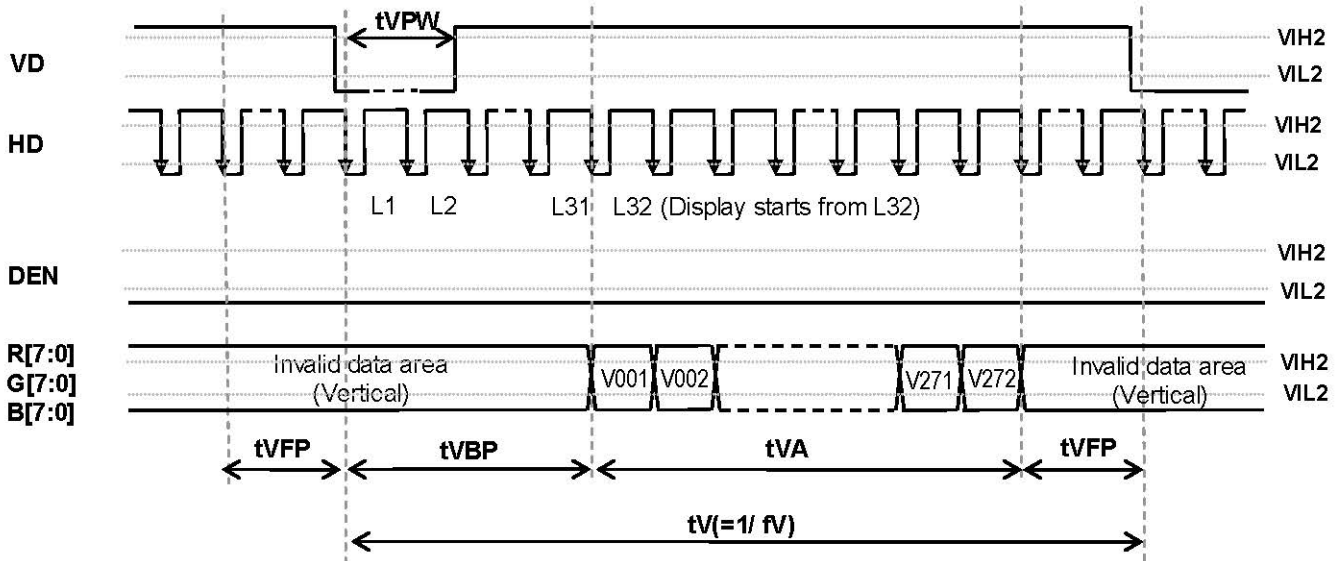

D. TIMING CHART3 (SETUP&HOLD TIME, OTHERS)

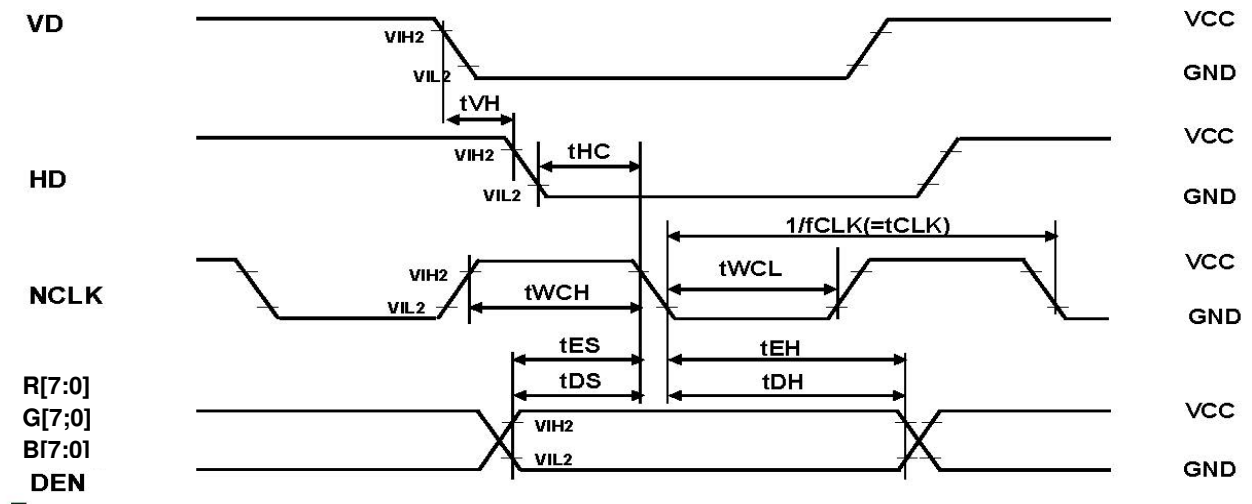

E. JITTER SPECIFICATION 1

Parameter	Min.	Typ	Max.	Unit	Remarks
Jitter range	-5	-	+5	%	Note1, 2, 3
Modulation frequency range	30	-	200	kHz	Note1, 2

Note 1: Applicable signals: NCLK, R0-R7, G0-G7, B0-7, HD, VD

Note 2: Data setup and data hold time of signal is according to the timing of A.SYNCHRONOUS MODE..

Note 3: NCLK frequency (f_{CLK}) described A.SYNCHRONOUS MODE means Jitter range 0%.

Note 4: KOE can't guarantee the influence to reliability and optical spec.

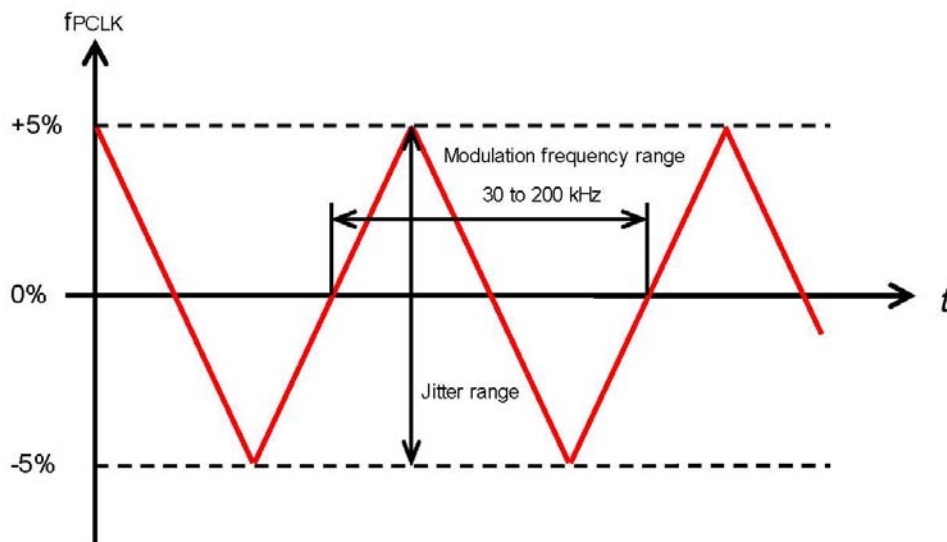

F. JITTER SPECIFICATION 2

Parameter	Min.	Typ	Max.	Unit	Remarks
Jitter range	-1.5	-	+1.5	%	Note1, 2, 3
Modulation frequency range	14.8	-	30.0	kHz	Note1, 2

Note 1: Applicable signals: NCLK, R0-R7, G0-G7, B0-7, HD, VD

Note 2: Data setup and data hold time of signal is according to the timing of 9.3 TIMING TABLE.

Note 3: NCLK frequency (fCLK) described 9.3 TIMING TABLE means Jitter range 0%.

Note 4: KOE can't guarantee the influence to reliability and optical spec.

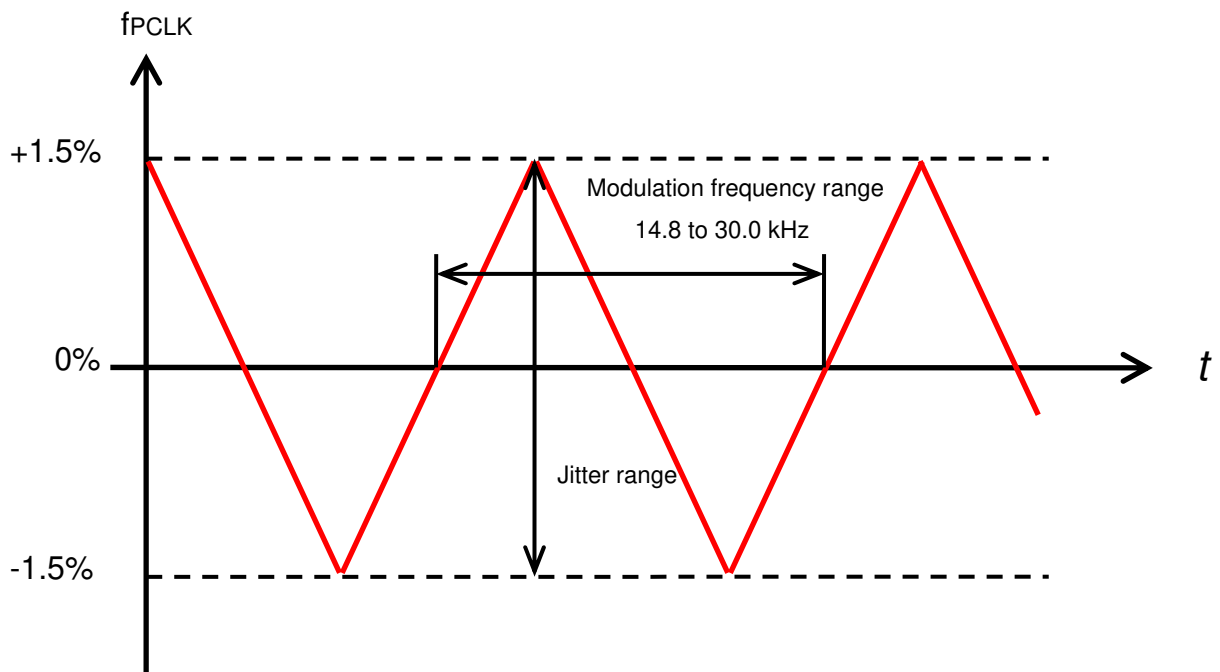

9.3 TIMING TABLE

Parameter		Symbol	Min.	Typ.	Max.	Unit	Description
Clock [NCLK]	Frequency	fCLK	9.34	9.70	11.19	MHz	
	Hi_Time	tWCH	20	-	-	ns	
	Lo_Time	tWCL	20	-	-	ns	
Data [R0-7,G0-7,B0-7]	Setup time	tDS	10	-	-	ns	
	Hold time	tDH	10	-	-	ns	
Horizontal sync. signal [HD]	Cycle	tH(t)	54.7	64.1	69.2	us	
		tH(clk)	612	622	646	ck	
	Pulse width	tHPW	5	-	tH-5	ck	
Vertical sync. signal [VD]	Cycle	tV	305	312	344	line	
	Pulse width	tVPW	2	-	TV-2	line	
Frame rate		fV	50	50	60	Hz	
Horizontal display period		tHA	480			ck	Only 480 ck
HD_NCLK phase difference		tHC	(tCLK/2) -8	tCLK/2	(tCLK/2) +8	ns	tCLK=1/fCLK
HD_VD phase difference		tVH	0	-	tH-1	ck	
Vertical front porch		tVFP	2	-	-	line	
Vertical back porch		tVBP	31			line	Only 31 line
Vertical display period		tVA	272			line	Only 272 line
Horizontal front porch		tHFP	16	-	-	ck	
Horizontal back porch		tHBP	116			ck	Only 116 ck

9.4 POWER ON/ OFF SEQUENCE

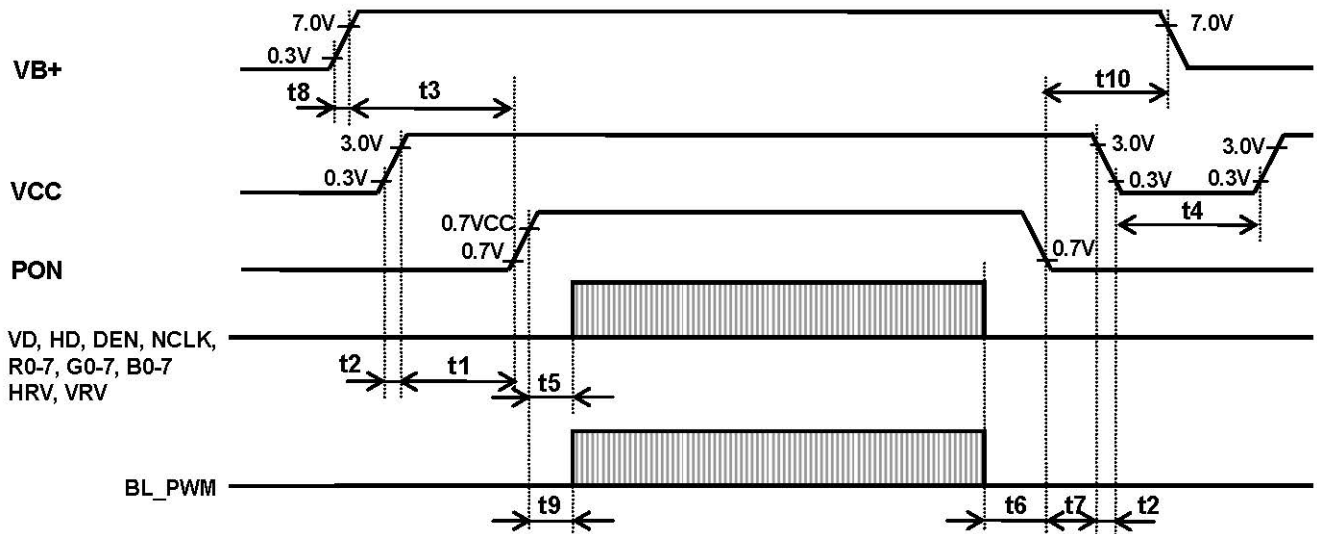

Symbol	Specification	Description
t1	$0 < t_1$	VCC power ON to PON starts timing.
t2	$0.2\text{ms} < t_2 \leq 10\text{ms}$	VCC rise and fall speed. (for reduce inrush current)
t3	$0 < t_3$	VB+ power ON to PON starts timing.
t4	$1000\text{ms} < t_4$	VCC power OFF / ON interval. (for discharge DCDC output voltage)
t5	$0 < t_5 \leq 10\text{ms}$	PON = High to input signal start timing.
t6	$t_6 \leq 10\text{ms}$	Input data stop to PON = Low timing.
t7	$0 \leq t_7$	PON = Low to VCC power OFF timing.
t8	$0.5\text{ms} < t_8 \leq 10\text{ms}$	VB+ rise speed. (for reduce inrush current)
t9	$0.2\text{ms} < t_9$	PON = High to BL_PWM signal start timing.
t10	$0 < t_{10}$	PON OFF to VB+ power OFF timing.

9.5 SCAN DIRECTION

Scan direction is available to be switched as below by setting CN1's VRV & HRV pin.

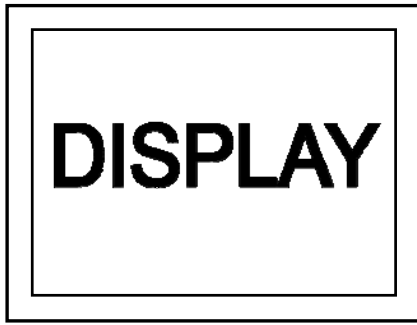

HRV : H ; VRV : H



HRV : L ; VRV : H



HRV : H ; VRV : L



HRV : L ; VRV : L

9.6 DATA INPUT for DISPLAY COLOR

Input color		Red Data								Green Data								Blue Data													
		R7	R6	R5	R4	R3	R2	R1	R0	G7	G6	G5	G4	G3	G2	G1	G0	B7	B6	B5	B4	B3	B2	B1	B0						
		MSB								LSB								MSB								LSB					
Basic Color	Black	L	L	L	L	L	L	L	L	L	L	L	L	L	L	L	L	L	L	L	L	L	L	L	L						
	Red	H	H	H	H	H	H	H	H	L	L	L	L	L	L	L	L	L	L	L	L	L	L	L	L						
	Green	L	L	L	L	L	L	L	L	H	H	H	H	H	H	H	H	L	L	L	L	L	L	L	L						
	Blue	L	L	L	L	L	L	L	L	L	L	L	L	L	L	L	L	H	H	H	H	H	H	H	H						
	Cyan	L	L	L	L	L	L	L	L	H	H	H	H	H	H	H	H	H	H	H	H	H	H	H	H						
	Magenta	H	H	H	H	H	H	H	H	L	L	L	L	L	L	L	L	H	H	H	H	H	H	H	H						
	Yellow	H	H	H	H	H	H	H	H	H	H	H	H	H	H	H	H	L	L	L	L	L	L	L	L						
	White	H	H	H	H	H	H	H	H	H	H	H	H	H	H	H	H	H	H	H	H	H	H	H	H						
Red	Black	L	L	L	L	L	L	L	L	L	L	L	L	L	L	L	L	L	L	L	L	L	L	L	L						
	Red(1)	L	L	L	L	L	L	H	L	L	L	L	L	L	L	L	L	L	L	L	L	L	L	L	L						
	Red(2)	L	L	L	L	L	L	H	L	L	L	L	L	L	L	L	L	L	L	L	L	L	L	L	L						
	:	:	:	:	:	:	:	:	:	:	:	:	:	:	:	:	:	:	:	:	:	:	:	:	:						
	Red(254)	H	H	H	H	H	H	H	L	L	L	L	L	L	L	L	L	L	L	L	L	L	L	L	L						
	Red(255)	H	H	H	H	H	H	H	H	L	L	L	L	L	L	L	L	L	L	L	L	L	L	L	L						
Green	Black	L	L	L	L	L	L	L	L	L	L	L	L	L	L	L	L	L	L	L	L	L	L	L	L						
	Green(1)	L	L	L	L	L	L	L	L	L	L	L	L	L	L	H	L	L	L	L	L	L	L	L	L						
	Green(2)	L	L	L	L	L	L	L	L	L	L	L	L	L	H	L	L	L	L	L	L	L	L	L	L						
	:	:	:	:	:	:	:	:	:	:	:	:	:	:	:	:	:	:	:	:	:	:	:	:	:						
	Green(254)	L	L	L	L	L	L	L	L	H	H	H	H	H	H	H	L	L	L	L	L	L	L	L	L						
	Green(255)	L	L	L	L	L	L	L	L	H	H	H	H	H	H	H	H	L	L	L	L	L	L	L	L						
Blue	Black	L	L	L	L	L	L	L	L	L	L	L	L	L	L	L	L	L	L	L	L	L	L	L	L						
	Blue(1)	L	L	L	L	L	L	L	L	L	L	L	L	L	L	L	L	L	L	L	L	L	L	L	H						
	Blue(2)	L	L	L	L	L	L	L	L	L	L	L	L	L	L	L	L	L	L	L	L	L	L	H	L						
	:	:	:	:	:	:	:	:	:	:	:	:	:	:	:	:	:	:	:	:	:	:	:	:	:						
	Blue(254)	L	L	L	L	L	L	L	L	L	L	L	L	L	L	L	L	H	H	H	H	H	H	H	L						
	Blue(255)	L	L	L	L	L	L	L	L	L	L	L	L	L	L	L	L	H	H	H	H	H	H	H	H						

10. OUTLINE DIMENSIONS

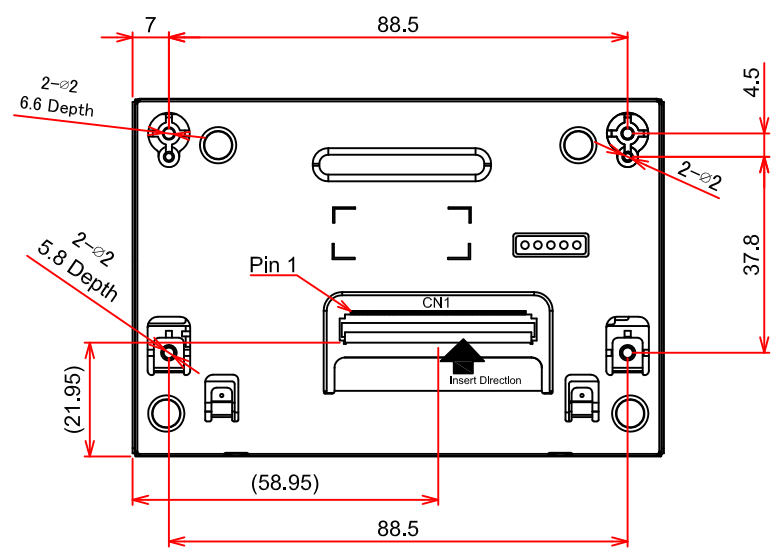
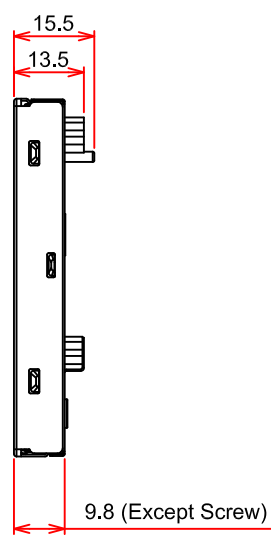
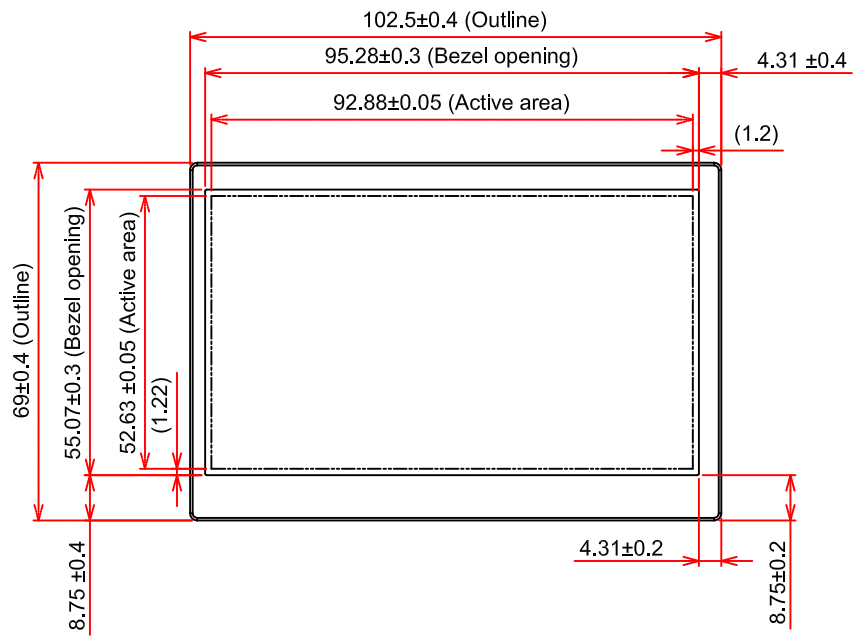

General Tolerance: ± 0.5 mm
 Scale : NTS
 Unit : mm

11. APPEARANCE STANDARD

11.1 CLASSIFICATION OF DEFECTS

Defects are classified as major defect and a minor defect according to the degree of defect defined herein.

a) Major defect

A major defect is a defect that is likely to result in failure, or to reduce materially the usability of the product for its intended purpose.

Function defect

abnormal operation including distinct R,G,B line defects and /or white line defect

b) Minor defect

A minor defect either is a defect that is not likely to reduce materially the usability of the product for its intended purpose, or is a departure from an established having little bearing on the effective use or operation of the product.

1).Dot defect. 2) Display non-uniformity. 3).Extraneous substances

4).Scratches. 5).Dents. 6).Current dissipation

Specific criteria of judgment on major and/or minor defects or otherwise shall be accordance with the attached "Classification of Defect"

11.2 ACCEPTABLE QUALITY LEVEL("AQL")

The AQL for major and minor defects shall be respectively set forth below.

a) Major defects: AQL :0.4

b) Minor defects: AQL :1.0

Note: If one bright dot is detected from the module that was supplied as a "0" bright dot module,
The agreed quantity of modules shall be secured as replacements apart from out compensation.

11.3 METHOD OF SAMPLING INSPECTION

a) Lot size : Quantity per shipment lot per model

b) Sampling type : Normal inspection, Single sampling

c) Inspection level : II

d) Sampling table : Table in ISO 2859-1

11.4 INSPECTION CONDITION

Item	Inspection Conditions
Ambient Illumination	Operating: 25 ~150 lux Non operating: 800~2000 lux
Ambient temperature	25±5°C
Ambient Humidity	60±20% RH
Viewing distance	350mm or more
Viewing angle	At perpendicular
How to use ND filter	Use ND filter open to eyes

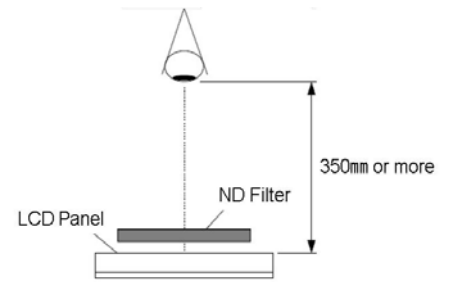

Fig.11-1

11.5 EXTERNAL INSPECTION

Average Diameter :D (mm), Length :L (mm), Width :W(mm)

Items to be inspected	Inspection Criteria			Note	
	No Count	Count			NG
Black or White Spots	$D < 0.15$	$0.15 \leq D \leq 0.50$	$N \leq 2$	$D > 0.50$	*1
Lint	$L < 0.15$ or $W < 0.05$	$0.15 \leq L \leq 3.0$ and $0.05 \leq W \leq 0.15$	$N \leq 2$	Others	*1
Scratch on the color filter and black mask	$L < 1$ or $W < 0.05$	$1 \leq L \leq 10$ and $0.05 \leq W \leq 0.15$	$N \leq 3$	Others	*1
Polarizer Scratch	$L < 1$ or $W < 0.05$	$1 \leq L \leq 10$ and $0.05 \leq W \leq 0.15$	$N \leq 2$	Others	*2
Polarizer Dent or Bubbles	$D < 0.15$	$0.15 \leq D \leq 0.50$	$N \leq 2$	$D > 0.50$	*2

***External Substance**

Note 1: Module operating (Black or White picture mode):

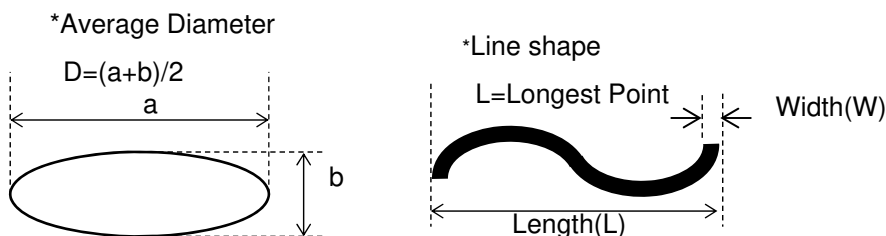

Note 2: Module non-operating (The External Visual Inspection):

The inspection shall be conducted by using a single fluorescent lamp for illumination, and viewable distance to LCD and from inspection eye shall be 350mm or more.

11.6 VISUAL INSPECTION

11.6.1 Zone

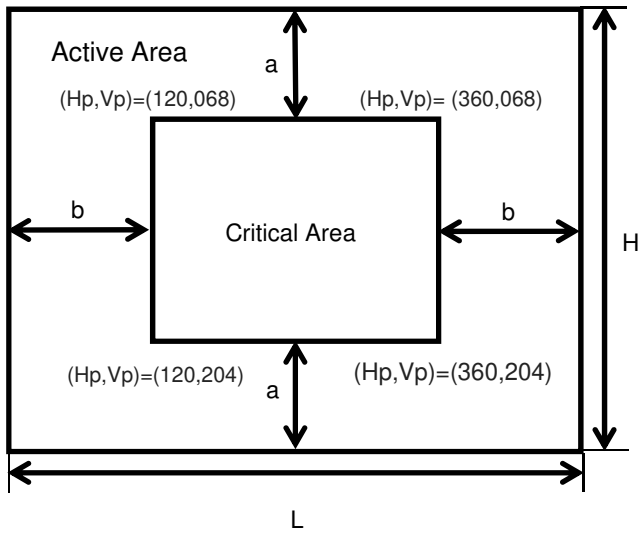

Fig.11-2

Effective Display Area(Active Area)
of specification about H,L

Critical Display Area(exclusion area)of
specification about a,b.
a,b; Critical Area $\geq 25\%$ Active Area

*Critical Area is defined as inside of the following
pixels.

(Hp, Vp)=(120,068)-(120,204)-(360,068)-(360,204)
:Refer to following Fig.11-2.

11.6.2 Define

No	Item		Define
A	Dot	Pixel	3 sub-pixels(R+G+B)
		Dot	1 sub-pixel (R or G or B)
B	Bright dot PPL Dot (pixel to pixel leak)	When the Module lights, dots appear bright on the display with a Black, Red, Green or Blue picture position.	
		Count	Visible through 5% ND Filter.
		No count	Not visible through 5% ND Filter.
C	Black dot	When the Module lights, dots appear black or faint color on the display with a White, Red, Green or Blue picture position.	
D	Black spot	When the Module lights, It appears circular shape extraneous substance with a black or white picture position.	
		Count	Visible through 5% ND Filter.
		No count	Not visible through 5% ND Filter.
E	Lint	When the Module lights, It appears linear shape extraneous substance with a black or white picture position.	
		Count	Visible through 5% ND Filter.
		No count	Not visible through 5% ND Filter.
F	Polarizar Scratch	When the Module no operating, It appears a scratch on the Polarizar.	
		Count	Based on size criteria <u>11.5 External Inspection.</u>
		No count	Based on size criteria <u>11.5 External Inspection.</u>
G	Polarizar Dent	When the Module no operating, It appears a dent on the Polarizar.	
		Count	Based on size criteria <u>11.5 External Inspection.</u>
		No count	Based on size criteria <u>11.5 External Inspection.</u>
H	Scratch on the color filter	When the Module lights, dots appear bright on the display with a Black, Red, Green or Blue picture position.	
		Count	Visible through 5% ND Filter.
		No count	Not visible through 5% ND Filter.
I	Scratch on the black mask	When the Module lights, dots appear bright on the display with a Black, Red, Green or Blue picture position.	
		Count	Visible through 5% ND Filter.
		No count	Not visible through 5% ND Filter.

11.6.3 Number of Transmission defects/(Acceptable)

Defect Description	Active Area	Critical Area
Bright Dot (including PPL Dot) (Note1)	0	0
Scratch on the Color Filter	0	0
Scratch on the Black Mask	0	0
Black Dot	3	0
Black spots (White spots)	2 (Note 2)	0
Lint	2(Note 2)	0
Total (operating)	3	0
Polarizer Scratch	2	0
Polarizer Dent	2	0
Total (no operating)	2	0

Note 1: Dots that blink shall be categorized as Bright Dot.

Note 2: Based on size criteria 11.5 External Inspection.

11.6.4 Defect distance & join

Item	Standards
Black dots distance	5mm or more *1
Black dots join(2 dots)	1(black dot) count *1
Black dots join(3 dots or more)	Not Allowed

Note 1:* Black dots join(2 dots) is counted as 1 Black dot defect. (Refer to following Fig.5-3.)

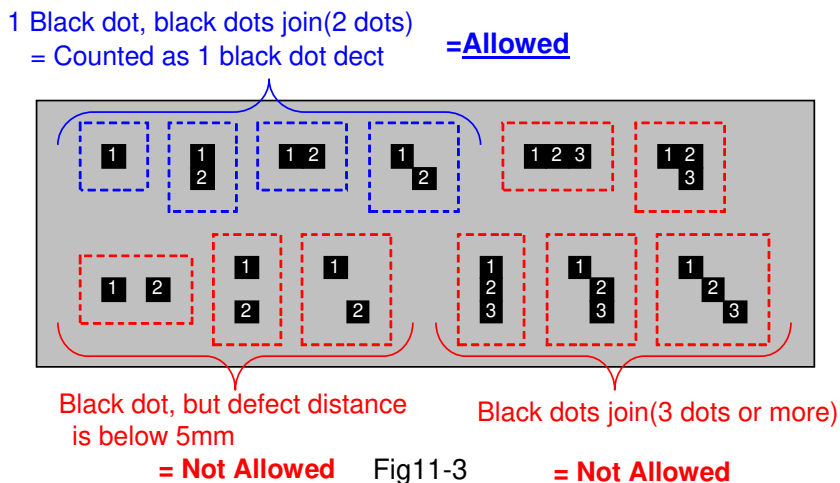

11.7 DISPLAY NON-UNIFORMITY

There should be no distinct non-uniformity visible through 2% ND Filter.

12. PRECAUTIONS

12.1 PRECAUTIONS of ESD

- 1) Before handling the display, please ensure your body has been connected to ground to avoid any damages by ESD. Also, do not touch display's interface directly when assembling.
- 2) Please remove the protection film very slowly before turning on the display to avoid generating ESD.

12.2 PRECAUTIONS of HANDLING

- 1) In order to keep the appearance of display in good condition; please do not rub any surfaces of the displays by sharp tools harder than 3H, especially touch panel, metal frame and polarizer.
- 2) Please do not pile the displays in order to avoid any scars leaving on the display. In order to avoid any injuries, please pay more attention for the edges of glasses and metal frame, and wear finger cots to protect yourself and the display before working on it.
- 3) Touching the display area or the terminal pins with bare hand is prohibited. This is because it will stain the display area and cause poor insulation between terminal pins, and might affect display's electrical characteristics furthermore.
- 4) Do not use any harmful chemicals such as acetone, toluene, and isopropyl alcohol to clean display's surfaces.
- 5) Please use soft cloth or absorbent cotton with ethanol to clean the display by gently wiping. Moreover, when wiping the display, please wipe it by horizontal or vertical direction instead of circling to prevent leaving scars on the display's surface, especially polarizer.
- 6) Please wipe any unknown liquids immediately such as saliva, water or dew on the display to avoid color fading or any permanently damages.
- 7) Maximum pressure to the surface of the display must be less than 1.96×10^4 Pa. If the area of adding pressure is less than 1 cm^2 , the maximum pressure must be less than 1.96N.

12.3 PRECAUTIONS OF OPERATING

- 1) Please input signals and voltages to the displays according to the values defined in the section of electrical characteristics to obtain the best performance. Any voltages over than absolute maximum rating will cause permanent damages to this display. Also, any timing of the signals out of this specification would cause unexpected performance.
- 2) When the display is operating at significant low temperature, the response time will be slower than it at 25 C° . In high temperature, the color will be slightly dark and blue compared to original pattern. However, these are temperature-related phenomenon of LCD and it will not cause permanent damages to the display when used within the operating temperature.
- 3) The use of screen saver or sleep mode is recommended when static images are likely for long periods of time. This is to avoid the possibility of image sticking.
- 4) Spike noise can cause malfunction of the circuit. The recommended limitation of spike noise is no bigger than $\pm 100 \text{ mV}$.

12.4 PRECAUTIONS of STORAGE

If the displays are going to be stored for years, please be aware the following notices.

- 1) Please store the displays in a dark room to avoid any damages from sunlight and other sources of UV light.
- 2) The recommended long-term storage temperature is between 10 C° ~35 C° and 55%~75% humidity to avoid causing bubbles between polarizer and LCD glasses, and polarizer peeling from LCD glasses.
- 3) It would be better to keep the displays in the container, which is shipped from KOE, and do not unpack it.
- 4) Please do not stick any labels on the display surface for a long time, especially on the polarizer.

13. DESIGNATION of LOT MARK

1) The lot mark is showing in Fig.13.1. First 4 digits are used to represent production lot, T represented made in Taiwan, and the last 6 digits are the serial number.

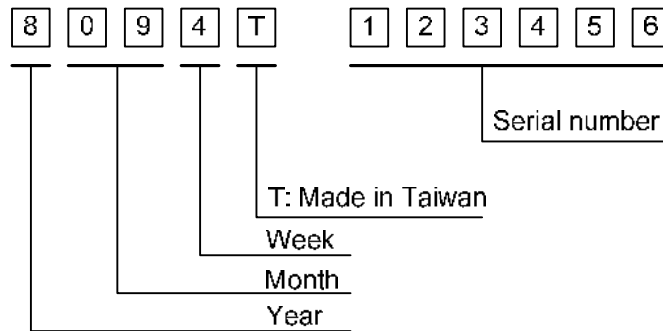

Fig. 13.1

2) The tables as below are showing what the first 4 digits of lot mark are shorted for.

Year	Lot Mark
2018	8
2019	9
2020	0
2021	1
2022	2

Month	Lot Mark	Month	Lot Mark
Jan.	01	Jul.	07
Feb.	02	Aug.	08
Mar.	03	Sep.	09
Apr.	04	Oct.	10
May	05	Nov.	11
Jun.	06	Dec.	12

Week	Lot Mark
1~7 days	1
8~14 days	2
15~21 days	3
22~28 days	4
29~31 days	5

3) Except letters I and O, revision number will be shown on lot mark and following letters A to Z.

4) The location of the lot mark is on the back of the display shown in Fig. 13.2.

Label example:

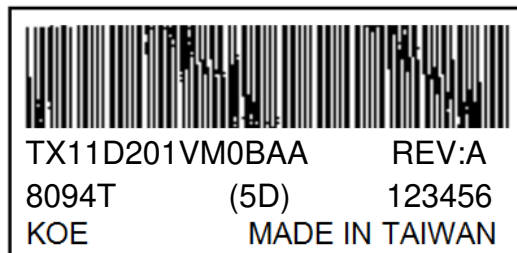

Fig. 13.2